

Z

V

A

COLLECTION 2014



Franco Zavarise  
ZAVA Founder

# ZAVA COLLECTION

ZAVA nasce nel 1982 dal talento creativo e dall'energia visionaria del suo titolare Franco Zavarise. Da allora, quella di ZAVA è una storia di affermazione continua, costruita su valori forti e radicati che contribuiscono a rendere inconfondibile la sua capacità manifatturiera. Oggi l'azienda può essere considerata una vera e propria eccellenza del made in Italy, fortemente radicata nel suo territorio e che opera nel più profondo rispetto per l'ambiente e per la qualità del lavoro.

Seguendo il suo naturale istinto per il design, Franco Zavarise coniuga fin dall'inizio la sua lunga esperienza nella lavorazione del metallo con una grande passione per l'illuminazione.

Nel suo stabilimento convivono la tradizione artigianale e le più avanzate tecnologie, mentre il lavoro abbozzato da macchinari di ultima generazione viene modellato da una sapiente e insostituibile lavorazione manuale. Questo connubio dà vita a un'articolata collezione di prodotti di illuminazione i cui tratti distintivi sono attenzione al design, creatività fuori dagli schemi e grande attenzione al dettaglio. Una collezione di lampade di indubbia personalità, la cui singolarità sta proprio nell'incontro tra la durezza, la matericità e la forza espressiva del ferro e la leggerezza impalpabile della luce.

*ZAVA was established in 1982, the product of the creative talent and visionary energy of its founder Franco Zavarise. Since then Zava's is a history of unrelenting successes, founded on strong, deep-rooted values that contribute towards making its manufacturing capabilities unmistakable. Today the business can be viewed as a true example of Italian manufactured excellence, strongly rooted in its local area and operating with the utmost respect for the environment and the quality of its work.*

*Right from the very outset Franco Zavarise followed his instinct for design by combining his long experience in metal working with his great passion for lighting.*

*In his factory artisan traditions operate alongside the most advanced technologies, whilst the work sketched out by the latest generation of machines is modelled by knowledgeable and matchless manual skills. This union gives life to an extensive collection of lighting products whose distinctive features include great care with the design, mould-breaking creativity and a huge amount of attention to detail. A collection of lamps with undoubted personality, where the distinctiveness is to be found in the hardness, the materiality and the expressive strength of the iron and the intangible lightness of the light.*

# DESIGNER



## ENRICO AZZIMONTI

Architetto e designer, parallelamente all'attività didattica presso lo IED di Milano e altre Università italiane, collabora con aziende come TVS, Lavazza, Guzzini, Coop, JVC, Diamantini&Domeniconi, Bosa, Pavoni Italia, Deutsche Bank. Alcuni suoi lavori sono esposti presso il Museu de les Arts Decoratives di Barcellona.

*Architect and designer, while teaching at IED Milan and other Italian universities, he collaborates with companies as TVS, Lavazza, Fratelli Guzzini, Coop, JVL, Diamantini&Domeniconi, Bilumen, Risolì, Bosa, Pavoni Italia, Deutsche Bank. Some of his works are exhibited at the "Museu de les Arts Decoratives" in Barcelona.*



## VALERIO COMETTI - V12 DESIGN

Laureato in Ingegneria Meccanica al Politecnico di Milano, fonda nel 2005 a Milano lo studio "Valerio Cometti+V12 Design". Collaborazioni: Brionvega (televisioni); Leucos (lampade); LaCimbali (macchine caffè); Riva1920 (mobili); Fiam Italia (vetro); Mediaset (elettronica); FEB31st (luxury eyewear). Dal 2009 è columnist di car design per Mondadori.

*Valerio Cometti, graduate in Mechanical Engineering from Milan's Polytechnic, establishes in 2005 "Valerio Cometti+V12 Design" in Milan. Collaborations: Brionvega (television); Leucos (lamps); LaCimbali (coffee machines); Riva1920 (furniture); Fiam Italia (glass); Mediaset (electronics); FEB31st (luxurious eyewear). Since 2009, Valerio Cometti is car design columnist for Mondadori.*



## LORENZO DAMIANI

Laureato in Architettura, si occupa di furniture e product design. Tre le mostre personali da ricordare: "Ma Dove Sono Finiti gli Inventori? Lorenzo Damiani" - Triennale design Museum nel 2009; "Prova a Prendermi" - Triennale 2012; "Lorenzo Damiani: Senza Stile" - Fondazione Achille Castiglioni 2012.

*Architecture graduate, does furniture and product design. Three of his exhibits to remember: "But where have all the inventors gone?" Damiani did at Triennale design Museum in 2009; "Catch me if you can" also at Triennale and "Lorenzo Damiani: Style-less" at Studio Museum Achille Castiglioni, both in 2012.*

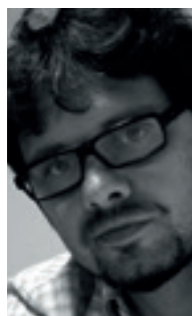

## DELINEODESIGN

Delineodesign (Giampaolo Allocco, Master in Industrial Design) sviluppa progetti multidisciplinari di industrial design. Aggiudicatosi 11 International Award, ha progetti esposti al Chicago Design Museum. Lavora per BMW Husqvarna, Lasportiva, Manfrotto, Scubapro, Ifi Industrie, Head, Gaber, Casamania, Doimo, Bosa Ceramiche e Kubico.

*Delineodesign Studio (Giampaolo Allocco, Master in Industrial Design) deals with all sorts of industrial design projects. He won 11 international awards and has projects displayed in the Chicago Design Museum. He works for BMW Husqvarna, Lasportiva, Manfrotto, Scubapro, Ifi Industrie, Head, Gaber, Casamania, Doimo, Bosa Ceramiche and Kubico.*



## MASSIMO ROSATI

Architetto, giornalista e blogger, si occupa da sempre di design e comunicazione. Dopo aver collaborato con i principali editori e aver diretto per 14 anni il mensile LA MIA CASA, ha fondato Designstreet.it, il web magazine dedicato al design contemporaneo. È designer per passione.

*Architect, journalist and blogger, always interested in design and communication. Having worked together with the main editors and having directed the monthly LA MIA CASA for 14 years, he founded Designstreet.it, the online magazine dedicated to contemporary design. He is a designer out of passion.*



## STUDIO 14

Nel 2010 il Designer Diego Bassetti e l'Architetto Andrea Panzieri, fondano lo studio di progettazione Studio 14. Collaborano con aziende leader: Casprini, Colico Design, Antonangeli, Bilumen, Sforzin, Mogg, Terzani, Diamantini & Domeniconi, Kundalini, Arkof Labodesign e sono pubblicati sulle principali riviste del settore.

*In 2010 Diego Bassetti - Designer and Andrea Panzieri - Architect, decided to make together the design studio "Studio 14". They work with leader companies: Casprini, Colico Design, Lighting Antonangeli, Bilumen, Sforzin Lighting, Mogg, Terzani, Kundalini, Arkof Labodesign and have been published in the main magazines.*



## PAOLO ULIAN

Industrial designer toscano di origine, nei primi anni 1990 è a Milano per lavorare con Enzo Mari. Ha vinto il "Design Report" Award e il premio "Dedalus". Collabora con Droog Design e con alcune aziende italiane tra le quali Driade, Fontana Arte, Zani e Zani, BBB Bonacina, Sensi&C., Coop, Skitsch.

*Industrial designer of Tuscan origin. In the early 1990's he was in Milan working with Enzo Mari. He won the "Design Report" Award and the "Dedalus" award as well. He works together with Droog Design and with Italian companies such as Driade, Fontana Arte, Zani e Zani, BBB Bonacina, Sensi&C., Coop and Skitsch.*



## FRANCO ZAVARISE

Franco Zavarise nasce a Mareeba, Australia, nel 1960. Dopo gli studi tecnici matura il desiderio di realizzare corpi illuminanti per gli amici di sempre. Nel 1982 fonda la ZAVA, una realtà dinamica in continua espansione. Crede nel design bello, accessibile e sostenibile.

*Franco Zavarise was born in Mareeba, Australia in 1960. After finishing his technical studies, he developed his great desire: to create lighting structures for his old friends. In 1982 he founded the dynamic and continuously growing ZAVA. He believes in great, affordable and sustainable design.*



# SISTER

BY ENRICO AZZIMONTI

Se posso spostare la luce dove voglio, se posso cambiare aspetto alla stanza facendo rimbalzare la luce ora sul tavolo, ora sulla parete, sul soffitto o sul divano... se posso avere un rapporto diretto con la forma e la funzione dell'oggetto e con le emozioni che l'oggetto è in grado di regalarmi... allora posso solo dargli un nome familiare...

*If I move the light where I want, if I can change the look of the room by bouncing the light now on the table, now on the wall, on the ceiling or on the sofa... if I can have a direct relationship with the form and function of the object and the emotions that the lighting object can give me... then I can just give it a familiar name...*



Ferro. Lampada orientabile sulla base, sullo stelo e sulla cupola. Combinazione colori a scelta. Classe energetica: {A}.

Iron. Orientable fitting on the base, on the tube and on the shade. Color matching on demand. Energy class: {A}.

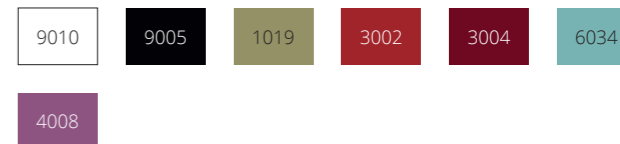



BRAND NEW

# SISTER

BY ENRICO AZZIMONTI



Ver. Ø31: 1x11W LED Ø 55mm 220Vac 3000K 675Lm En. class A  
 Ver. Ø24: 1x7W LED Ø42mm 220Vac 3000K 430Lm En. class A

1x11W LED Ø 55mm 220Vac 3000K 675Lm Energy class A

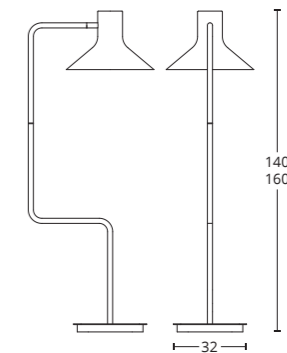
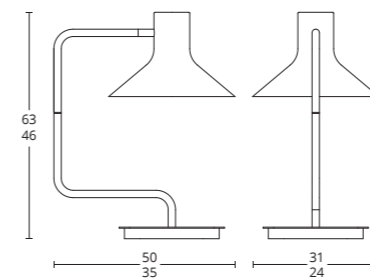

1x7W LED Ø42mm 220Vac 3000K 430Lm Energy class A

1x11W LED Ø 55mm 220Vac 3000K 675Lm Energy class A

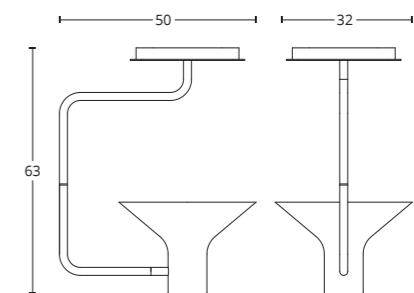
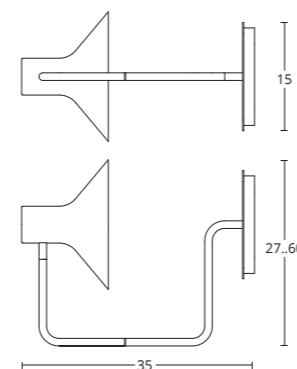



# SISTER

BY ENRICO AZZIMONTI

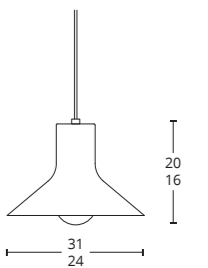

Ferro. Versione a LED: Classe energetica: {A}. Versione con attacco E27 (lampadina esclusa): Classe energetica: {A++ -> E}.

Iron. Version with LED: Energy class: {A}. Version with lampholder E27 (bulb not included): Energy class: {A++ -> E}.

LED version Ø24: 1x7W LED Ø42mm 220Vac 3000K 430Lm En. class A  
LED version Ø31: 1x11W LED Ø55mm 220Vac 3000K 675Lm En. class A

# T-LAMP

BY ENRICO AZZIMONTI

Uno stelo nell'atto di interpretare la natura. E' come se la corrente fosse linfa, il montante il tronco, la diramazione l'innesto, gli steli laterali i rami e la luce i frutti.

*A stem in the act of interpreting the nature. It is like the current was lymph, the upright was the trunk, the T-junction was the union and the side-stems were the branches and light was the fruits.*

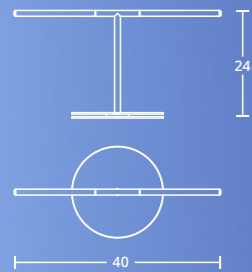

Ferro. LED incluso. Luce orientabile orizzontalmente, cavo avvolgibile nella base. Classe energetica: {A}.

*Iron. LED included. Horizontally adjustable light. Cord storage in the base. Energy class: {A}.*

1x1,5W Strip LED 24Vcc 4000K 184Lm Energy class A



BRAND NEW



1x5,5W Strip LED 5,5W 24Vcc 4000K 403Lm Energy class A



- 9010
- 9005
- 7016
- chrom



**ZAK** BY ENRICO AZZIMONTI

BRAND NEW

Allogena, ad incandescenza o a LED, questa lampada mette in scena le sue differenti fonti luminose che, attraverso la lettura delle loro forme amorphe, ne completano il design. Una grande lampadina alogena con coprilampada asportabile crea la luce d'ambiente gestibile attraverso la dimmerazione andando ad aumentare o diminuire l'intensità della luce emessa. Una piccola lampadina ad incandescenza, quando accesa, diventa un piccolo lume di cortesia per chi proprio... il buio non lo sopporta! Quando manca la corrente entrano in funzione i LED che, alimentati a pile ricaricate attraverso la rete elettrica, si accendono al cessare dell'alimentazione diretta. Il suo nome deriva dall'essere celatamente anche lampada d'emergenza che... Zak si illumina, quando Zak... manca la corrente!

Halogen, incandescent or LED, this lamp is staging its different light sources that, through their amorphous forms, they complement the design. A large halogen bulb with a removable cover creates an environmental light effect by dimming the light intensity. A small incandescent bulb, when turned on, it becomes a little courtesy light for those who just... can not stand darkness! When a power failure brought into the house, some LED lights, powered by rechargeable batteries, turn on the light again. From this function comes the name of this lamp from being secretly even an emergency light that... Zak, Zak... it turns on when the power fails!

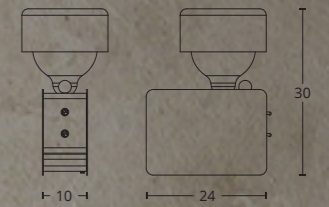
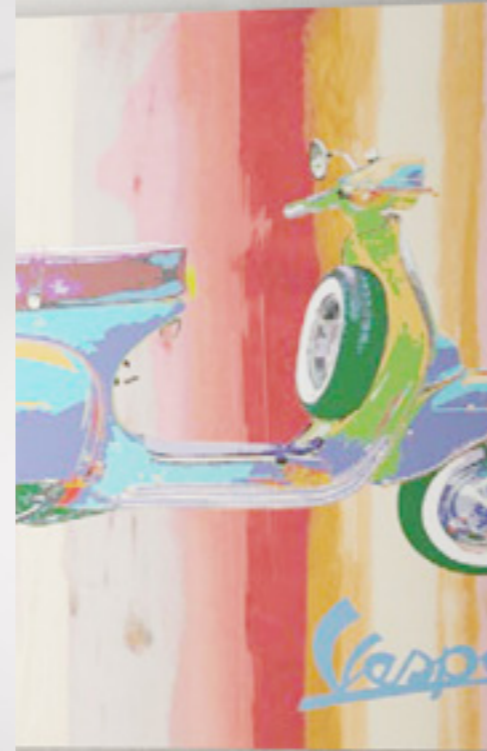

base

9010

struttura / structure

9005

7006

3002

6018

4005

1019

Ferro. Paralume su richiesta. Disponibile anche versione con luce d'emergenza 2x1W LED 350mA 3V 3000K 80Lm (Autonomia: 3 ore), Classe energetica: {A++ -> E}.

Iron. Lamp Shade on request. Available also with emergency light 2x1W LED 350mA 3V 3000K 80Lm (Battery life: 3 hours). Energy class: {A++ -> E}.

1x70W 230V E27 3000K Energy class C. 1x10W 230V E14 3000K Energy class C







# SKETCH

BY ENRICO AZZIMONTI

Ho sempre pensato che l'oggetto lampada prenda forma dalla fonte luminosa attraverso un pensiero progettuale volto alla risoluzione di bisogni... sul foglio si schizza la lampadina, si aggiunge un piano di appoggio, magari un archivio per libri o musica e, perché no, infiniti profili di lampade che avvolgono la luce...

*I always thought that the lighting object takes shape from the light source, through a design concept aimed at the resolution of needs... on the sheet the bulb is sketched, a ground plane is added, maybe a repository for books or music, and why not, infinite profiles of lamps which envelop the light...*

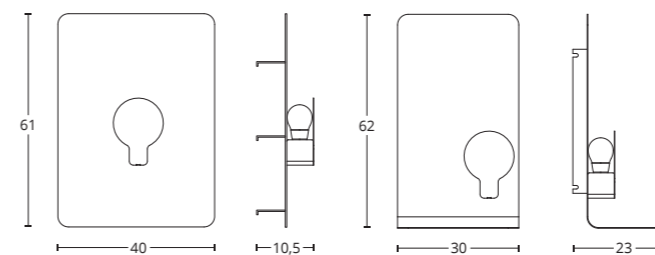

- 9010
- 3004
- 2004
- 9005
- 7016
- 1019

Ferro. Disponibile anche versione con superficie scrivibile con pennarelli per lavagna bianca. Classe energetica: {A++ -> E}.

Iron. Available also with writable surface with markers for the whiteboard. Energy class: {A++ -> E}.

1x11W E27 230V 4000K 550lm Energy class A



# SKETCH

BY ENRICO AZZIMONTI

Ferro. Disponibile anche versione con superficie scrivibile con pennarelli per lavagna bianca. Su richiesta luce di lettura con tubo flessibile in ottone cromato Ø9,8xL500mm con LED 3W 350mA 9V 3000K 280Lm. Classe energetica: {A++ → E} e {A}.

*Iron. Available also with writable surface with markers for the whiteboard. On request flexible chrome-plated brass reading light Ø9,8xL500mm with LED 3W 350mA 9V 3000K 280Lm. Energy class: {A++ → E} and {A}.*

1x11W E27 230V 4000K 550lm Energy class A

BRAND NEW

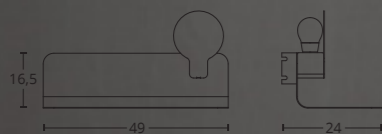

9010 3004 2004 9005 7016 1019



Ferro. Disponibile anche versione con superficie scrivibile con pennarelli per lavagna bianca. Classe energetica: {A++ → E}.

*Available also with writable surface with markers for the whiteboard. Energy class: {A++ → E}.*

1x11W E27 230V 4000K 550lm En. class A



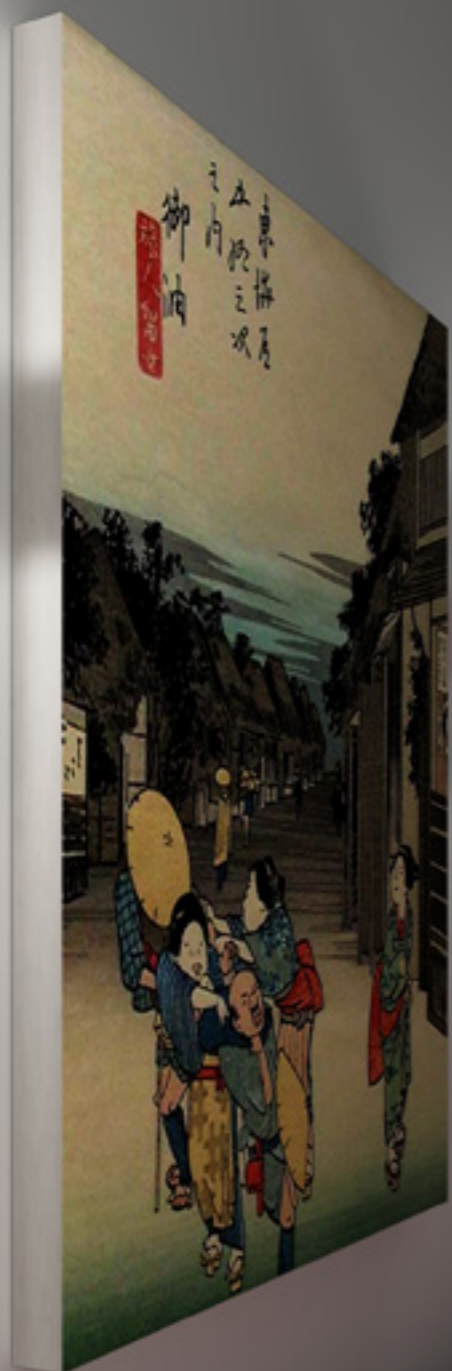

# MANTA

BY ENRICO AZZIMONTI

Due ali bianche libere. Libere di posarsi sui muri, libere di aggrapparsi ai soffitti, libere di mostrarsi verticali, orizzontali, inclinate. Libere di rimanere sole, aggregarsi in coppia o a gruppi, allinearsi, riprodursi in serie affiancandoci nei gesti quotidiani.

*Two free white wings. Free to settle on the walls, free to cling to the ceilings, free to show off vertical, horizontal, inclined lines. Free to be alone, in pairs or in groups, to join, to align, to reproduce themselves in the daily routine.*

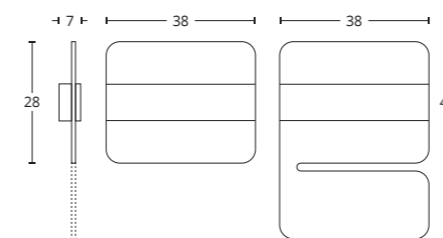

Ferro. Disponibili anche nella versione lampade d'emergenza in caso di black-out (autonomia 3 ore) e nella versione "Manta Sign" con scritte personalizzabili su richiesta, al taglio laser o adesive. Classe energetica: {A}.

*Iron. Also available with emergency light in case of power failure (Battery life: 3 hours) and in the "Manta Sign" version with customized texts on demand, that could be both laser cut or adhesive. Energy class: {A}.*

2x48 LED Line cm.28 4000K 1426Lm Energy class A  
Emergency Lights + 1x3W LED 24V 4000K 300Lm  
Energy class A

Base 9010

Fascia: colore a scelta (vedi tabella colori RAL)  
Band: color on demand (see RAL color chart)





# MODELS

BY ENRICO AZZIMONTI

Un connubio tra fashion e design... Aggiungendo o sottraendo moduli all'abito delle Models si ottengono lampade piccole e grandi a luce diffusa o concentrata con un gesto naturale... quasi sartoriale.

*A union of fashion and design... Adding or removing modules from the Models' outfit produces small and large lamps with diffused or concentrated lighting with a natural gesture... almost sartorial.*

Ferro. Attacco E27. Lampadine escluse. Classe energetica: {A++ -> E}.  
Iron. Lampholder E27. Bulb not included. Energy class: {A++ -> E}.

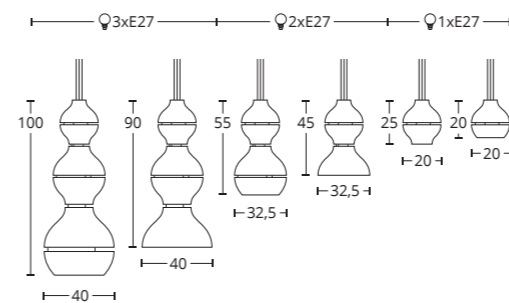

- 9010
- 9005
- 3002
- 4005
- 4008
- 1019
- 6018



# ZENA

BY ENRICO AZZIMONTI

» Vorrei avvicinarmi almeno un poco alla solidità e forza interiore delle donne... a quei nascosti risvolti così positivamente pragmatici, quei pensieri ed energie "multitasking" racchiuse in differenti irraggiungibili forme estetiche... con Zena... un omaggio alla bellezza d'intelletto...

*I would like at least be a little closer to the solidity and inner strength of women... those hidden aspects so positively pragmatic, those thoughts and "multitasking" energies enclosed in different and unattainable aesthetical shapes... with Zena... a tribute to the beauty of intellect ...* «



## LED

Cupola in vetro soffiato (Made in Italy). Base in ferro. Nr.170 quadrati in vetro 16x16mm. Versione LED con alimentazione a spina o a batteria ricaricabile (autonomia: 3 ore). Cristallo in dotazione: trasparente. Classe energetica: {A}.

*Blown glass dome (Made in Italy). Iron base. Nr.170 Diamond shaped glass 16x16mm. LED version with power pack plug or rechargeable battery (Battery life: 3 hours). Crystal included: transparent. Energy class: {A}. 1x3W LED 3000K 12V 300Lm Energy class A*

BRAND NEW



chrome

9010

## Candela / Candle

Cupola in vetro soffiato Made in Italy. Nr.170 quadrati in vetro 16x16mm. Base in ferro.

*Blown Glass dome Made in Italy. Nr.170 squares shaped glass 16x16mm. Iron base.*

# GHERKIN

BY ENRICO AZZIMONTI



## LED

Ferro. Versione LED con alimentazione a spina o a batteria ricaricabile (autonomia: 3 ore). Cristallo in dotazione trasparente. Classe energetica: {A}.

*Iron. LED version with power pack plug or rechargeable battery (Battery life: 3 hours). Crystal included: transparent. Energy class: {A}.*

1x3W LED 3000K 12V 300Lm Energy class A

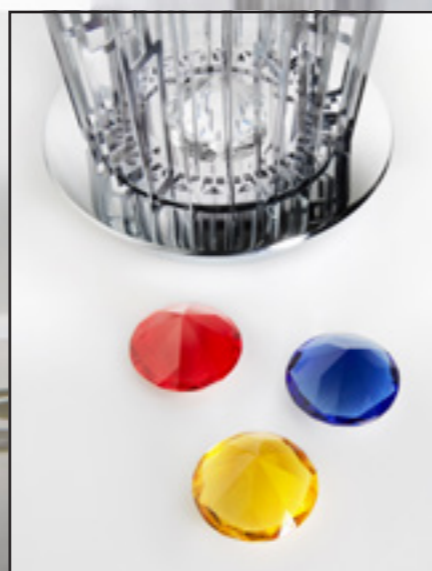

Un omaggio ai simboli architettonici delle city sparse nel mondo che vivono un momento storico di competizione tecnica, estetica e d'intelletto riportando la pulsione verso il cielo nelle nostre case attraverso una luce posta nelle "fondamenta" di un iconico grattacielo come paralume.

A tribute to the architectural symbols of the cities spread around the world that have been living a historic moment of technical, aesthetics and intellectual competition, bringing the energetic movement towards the sky in our homes, through a light placed in the "foundations" of an iconic skyscraper shade.



## Candela / Candle

Ferro.  
Iron.

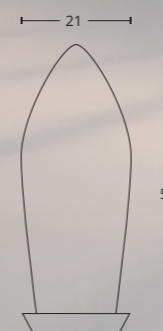

9010

9006

chrome

BRAND NEW

# CONCRETE

BY ENRICO AZZIMONTI

Ci si aspetta che una libreria sia solida come il cemento, sia realmente in grado di adattarsi alle necessità di archiviazione, sia flessibile, aggregabile, interpretabile nel tempo così da rendere la vita più positiva. Ricercando questi valori ho lavorato con materiali naturali enfatizzandone le caratteristiche estetiche e tecniche alla ricerca di una forma pulita ed essenziale in grado di adattarsi ai pensieri delle persone.

*It is expected that a library is as solid as the concrete, it is really able adaptable to the needs of storage, it is flexible, aggregated, interpreted over time so as to make life more positive. By Researching these values I have worked with natural materials emphasizing the aesthetic and technical characteristics, looking for a clean and simple form adaptable to the thoughts of people.*

Legno pioppo naturale / struttura in ferro blu di laminazione. Libreria modulare. Cubi in legno posizionabili in altezza a piacere.

*Natural poplar / structure in blue iron. Modular Bookshelf. Wooden cube adjustable up and down as you wish.*

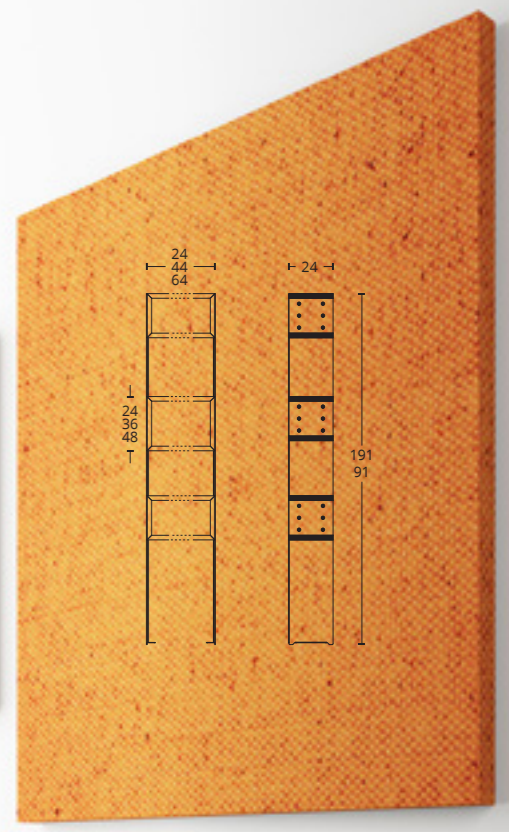

BRAND NEW

# BUSTIER

BY VALERIO COMETTI - V12 DESIGN

“Bustier” è una compatta lampada da tavolo che dimostra il grande virtuosismo di Zava nella lavorazione del metallo. Una sinuosa struttura di metallo avvolge la sorgente luminosa e suggerisce l'archetipale sagoma di un paralume. Metallo e luce giocano ed interagiscono, proiettando un gioco di ombre sempre in movimento e mai identico: ipnotico e rilassante, in base allo stato d'animo di chi lo osserva.

*“Bustier” is a compact table lamp that shows the great virtuosity of Zava in the metal processing. A sinuous metal structure surrounds the light source and suggests the archetypal shape of a lampshade. Metal and light play and interact, casting a shadow effect on the go and it is never the same: hypnotic and relaxing, depending on the state of mind of the observer.*

9005

9010

2004

chrome

Cavo: colore a scelta (vedi tabella colori cavi)  
Cable: color on demand (see cables color chart)

Ferro. Classe energetica: {C}.  
Iron. Energy class: {C}.

1x42W E27 230V 3000°K  
halogen Energy class C

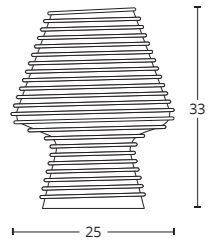

BRAND NEW







# RINGS

BY VALERIO COMETTI - V12 DESIGN



Famiglia di lampade pensate per il contract e più in generale per installazioni importanti. Volevo dare all'interior designer o al cliente finale, la possibilità di "disegnare" forme e descrivere volumi scultorei in libertà e con grande leggerezza, fornendo loro degli anelli di luce, rigidi, ma eterei. Mi piaceva l'idea di prestare la mia progettualità, il mio design ad altri professionisti, creando un semplice alfabeto, fatto di differenti diametri, di traiettorie libere e di luce per poter comporre queste mie "lettere" con grande inventiva e creare installazioni di grande impatto.

*A family of lamps designed for the contract and more generally for major installations. I wanted to give to the interior designers or to the end customers the chance to "draw" shapes and describe sculptural volumes freely, by providing rings of light that are stiff, but ethereal at the same time. I liked the idea of offering my project concept, my design to other professionals, creating a simple alphabet, made of different diameters and light-free path to be able to compose these "letters" with great inventiveness and create high-impact installations.*



Aluminio. Gli anelli di Rings sono disponibili in diversi diametri. Ogni anello è indipendente ed è possibile creare composizioni di qualsiasi forma e dimensione. Striscia LED inclusa. Classe energetica: {A}.

*Aluminium. Rings structures are available in different diameters. Each ring is independent and it is possible to create compositions of any shape and size. LED strip included. Energy class: {A}.*

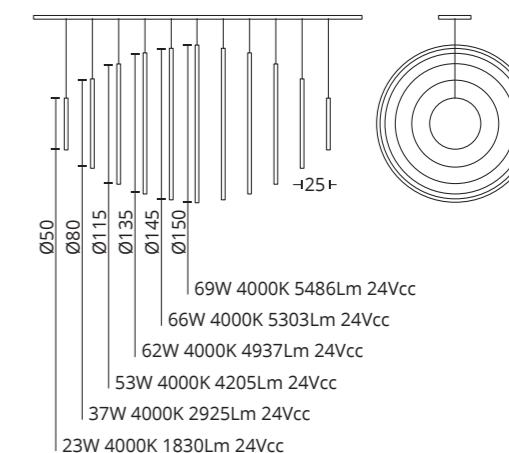



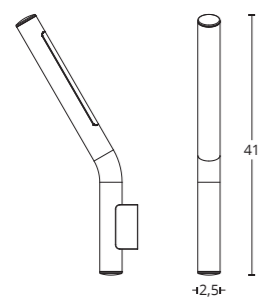

chrome 9010

Ferro. Classe energetica: {A}.  
Iron. Energy class: {A}.

1x7W striscia LED 24V 4000K 950Lm Energy class A



# TUBE

BY VALERIO COMETTI - V12 DESIGN

La definizione delle forme dei componenti della famiglia "Tube" nasce dallo studio delle diverse esigenze illuminotecniche negli ambienti domestici e contract, esigenze che sono divenute stimolo e guida per la definizione formale del progetto. La semplicità delle loro forme segue un principio di "design silenzioso", caro a Valerio Cometti, secondo il quale il design deve anche saper diventare garbato strumento di valorizzazione degli spazi e non sempre esigente primadonna.

The definition of the forms that are composing the "Tube" collection comes from the study of the different lighting needs in domestic and contract requirements that have become an incentive and guide for the formal definition of any project. The simplicity of their forms follows a principle of "silent design", very appreciated from Mr. Valerio Cometti, according to which the design must also just be a gentle tool to emphasize the spaces and do not always be a demanding prima donna anyway.

Ferro. Disponibile anche versione con luce inferiore d'emergenza (Autonomia: 3 ore). Classe energetica: {A}.

Iron. Available also with light emergency on the lower part (Battery life: 3 hours). Energy class: {A}.

1x3W strip LED 24V 4000K 300Lm En. class A  
1x7W strip LED 24V 4000K 950Lm En. class A





# FRECCIA

BY LORENZO DAMIANI

Freccia è una lampada da tavolo a doppia illuminazione che si manifesta come innesto di due unità distinte: forte è la sensazione di una fusione di elementi solitamente disgiunti.

*Freccia is a table lamp with a twin illumination that manifests itself as the grafting of two distinct units: there is a strong sensation of a fusion of usually disconnected elements.*



Ferro. Luce di lettura orientabile. Doppia accensione su cavo on/off. Classe energetica: {A e A++ -> E}.

*Iron. Orientable reading light. Double illumination on/off. Energy class: {A and A++ -> E}.*

1x105W E27 230V 3000°K Halogen Energy class D  
1x7W LED 220Vac Ø42mm 3000K 430Lm En. class A

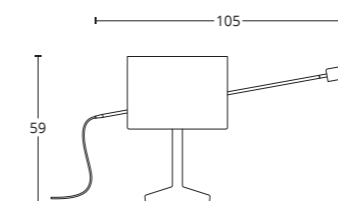

- |                    |  |                               |
|--------------------|--|-------------------------------|
| esterno<br>outside | <input checked="" type="checkbox"/> 9005 | <input type="checkbox"/> 9010 |
| interno<br>inside  | <input type="checkbox"/> 9010            |                               |

# OMBRA

BY LORENZO DAMIANI

Il movimento "a compasso" dei quattro elementi indipendenti permette di indirizzare la luce, illuminando l'ambiente circostante attraverso dei contrasti di luce e ombra.

*The "compass-like" movement of the four independent elements allows the light to be aimed, illuminating the surrounding environments with contrasts of light and shade.*

Corpo centrale paralume in stoffa, alette laterali in alluminio e tubo di sostegno in ferro. Attacco E27. Lampadina esclusa.  
Classe energetica: {A++ -> E}.  
*Central body as a fabric shade, lateral small wings in aluminium and hanging tube in iron. Lampholder E27. Bulb not included.  
Energy class: {A++ -> E}.*

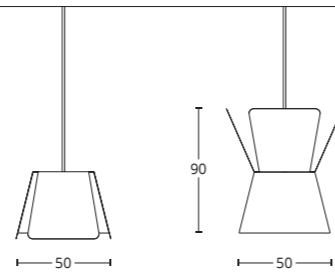

esterno outside	9010	9005	3004	4008
interno inside	9010			



# DADÌ

BY DELINEODESIGN

Decisa, irregolare e inaspettata... Dadì non è mai uguale a se stessa e, da qualsiasi punto di vista la si osservi, cambia aspetto e proporzioni con geometria naturale. La lampada Dadì nasce da un foglio metallico piegato per creare un volume monolitico, interrotto e ritmato dai tagli diagonali.

*Determined, irregular and unexpected... Dadì is never the same, and from any point of view it is observed, it changes aspect and geometric proportions very easily. The lamp Dadì comes from a metal sheet folded in order to create a monolithic volume, interrupted and patterned by diagonal cuts.*

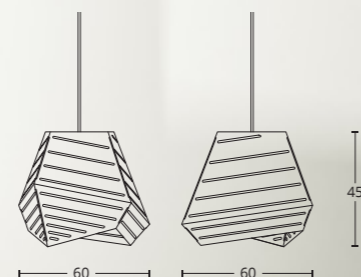

Ferro. Attacco E27. Lampadina esclusa.  
Classe energetica: {A++ -> E}.  
Iron. Lampholder E27. Bulb not included.  
Energy class: {A++ -> E}.

9010

Cavo: colore a scelta (vedi tabella colori cavi)  
Cable: color on demand (see cables color chart)

BRAND NEW



# LIBRA

BY DELINEODESIGN

Libra è una lampada che ha bisogno di un libro. Altrimenti cade. Così d'ora in poi saremo obbligati ad averne una copia (già letta) sempre vicino a noi.

*Libra is a lamp that is in need of a book. Otherwise if falls over. So from now on we are compelled to have a copy (already read) near us always.*



Ferro. Classe energetica: {A}.  
 Iron. Energy class: {A}.  
 1x2,9W strip LED 24Vcc 4000K 222lm Energy class A

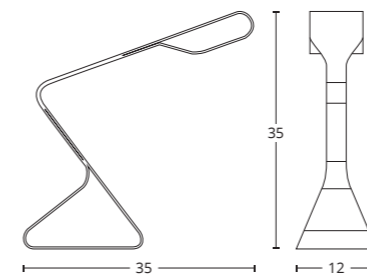

esterno pellicola adesiva:  
 outside adhesive film:



interno  
 inside colore personalizzabile su richiesta  
 any color on demand





# GROWN

BY DELINEODESIGN

Una famiglia di lampade realizzata da una sequenza in filo di ferro che ritmicamente giocherà con la luce: la taglierà, la amplificherà, la disturberà, la disegnerà.

*A family of lamps created from a sequence of wire thread that will rhythmically play with the light: it will cut it, amplify it, disturb it, draw it.*

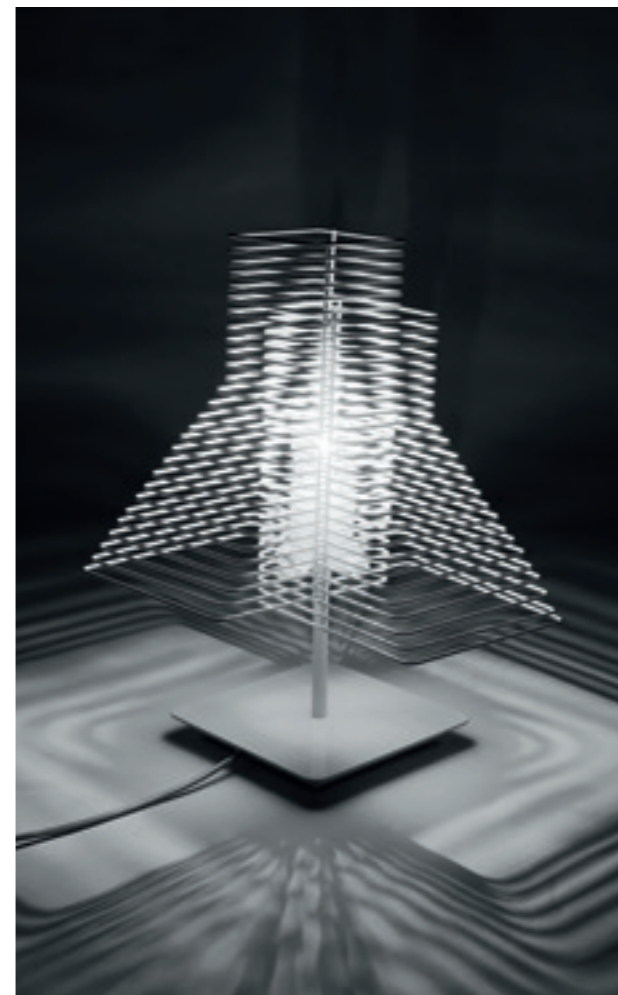



# GROWN

BY DELINEODESIGN

Ferro. Attacco E27. Struttura tondino Ø 4 mm.

Classe energetica: {A++ → E}.

Iron. Lampholder E27. Structure rod Ø 4 mm.

Energy class: {A++ → E}.

(A) 1x105W E27 230V 3000°K halogen Energy class D

(B) 1x42W E27 230V 3000°K halogen Energy class C

(C) 1x105W E27 230V 3000°K halogen Energy class D

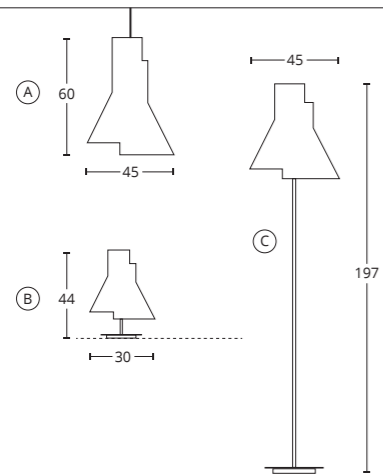

9005  
opaque

9010  
opaque

rame  
copper

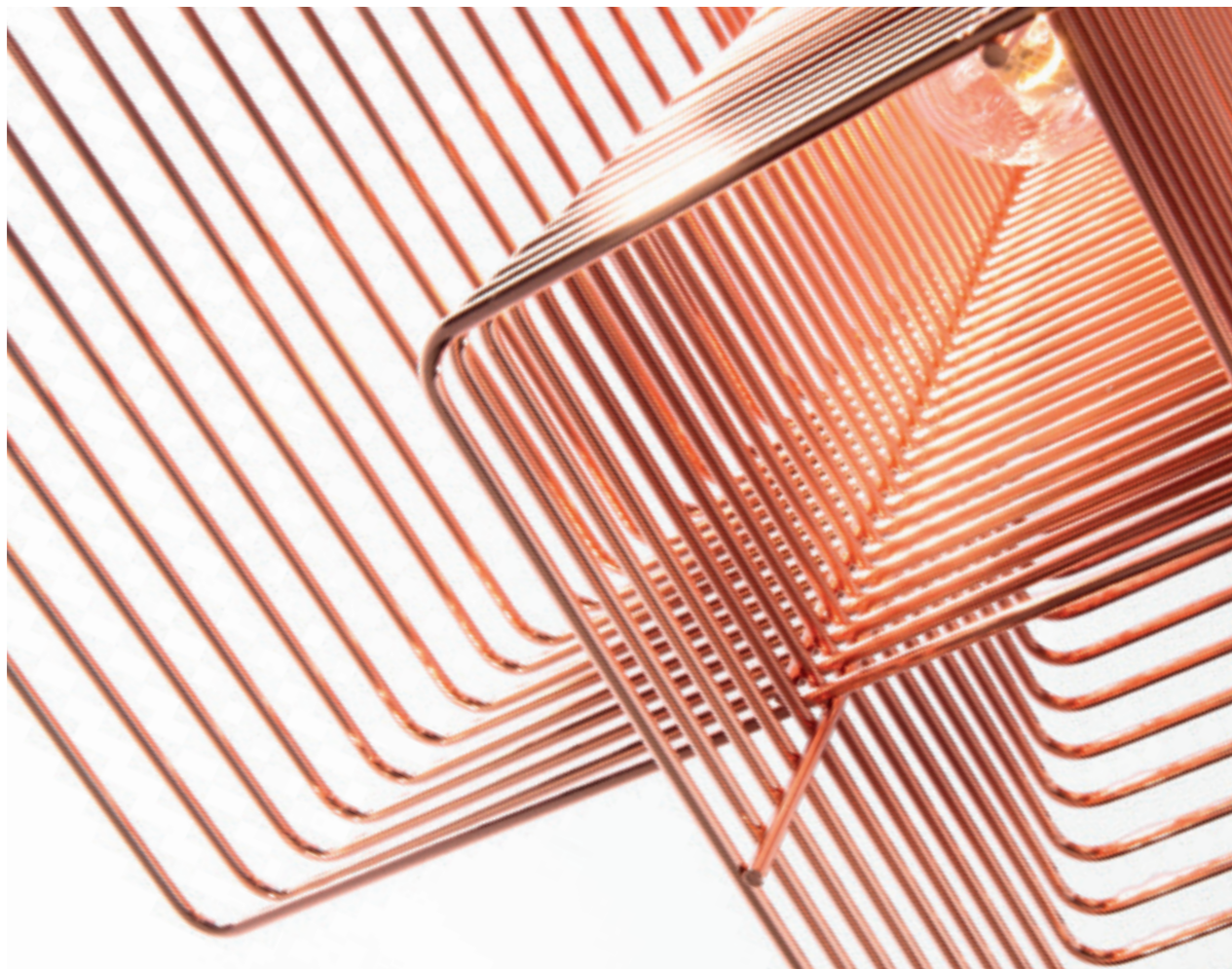
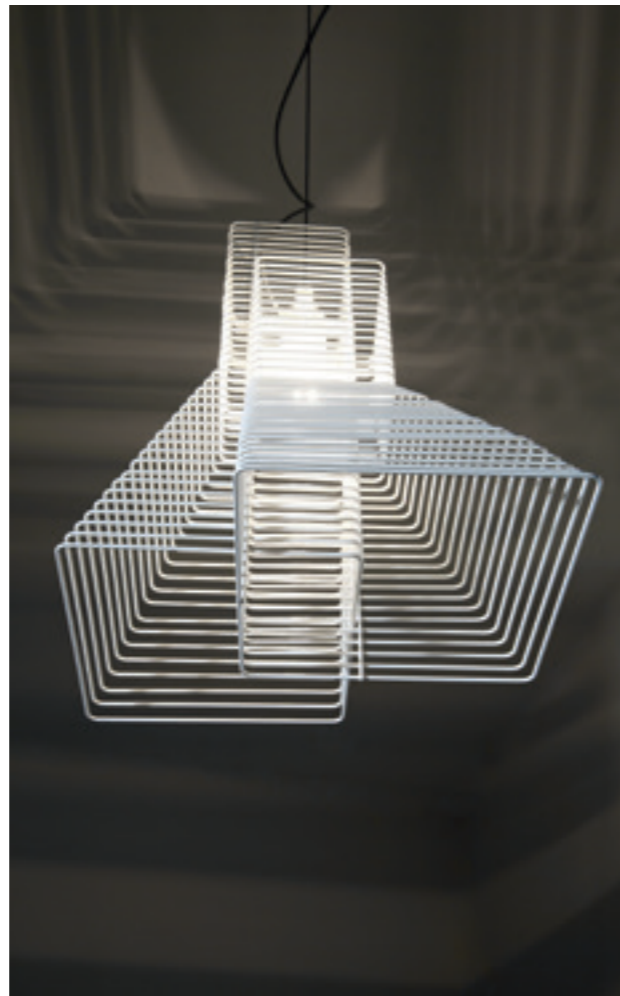



# ICON X

BY MASSIMO ROSATI

Più che una lampada, la sua essenza. La sua icona, disegnata da una linea spezzata, composta da dieci segmenti. Ecco Icon 10.

More than a lamp, there is its essence. Its icon, drawn by a broken line, consists of ten sections. That's Icon 10.

Alluminio. Attacco E27. Lampadina esclusa. Classe energetica: {A++ -> E}.  
Aluminium. Lampholder E27. Bulb not included. Energy class: {A++ -> E}.

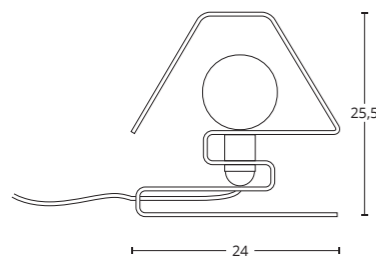

- 9010
- 1019
- 2004
- 3002
- 6034
- 6018

# ICON X-MAS BY MASSIMO ROSATI

La piccola lampada da tavolo Icon X si presenta nella sua versione natalizia dove il paralume, realizzato in metallo tagliato al laser e piegato, assume la forma iconica dell'albero di Natale.

The small table lamp Icon X is presented in its Christmas version where the lampshade, made of laser cut and folded metal, takes on the iconic shape of the Christmas tree.

3002

6005

Alluminio. Attacco E27. Lampadina esclusa. Classe energetica: {A++ -> E}.  
Aluminium. Lampholder E27. Bulb not included. Energy class: {A++ -> E}.



# ICON X MINI BY MASSIMO ROSATI

La più iconica delle lampade riduce le sue dimensioni e si trasforma in una piccola, ironica lanterna. Per arredare una finestra, un camino, una mensola o per una cena a lume di candela.

*The most iconic of the lamps reduces its size and turns into a small, ironic lantern. Thought to decorate a window, a fireplace, a shelf or a dinner by candlelight.*

Alluminio. Scritte al taglio laser personalizzabili su richiesta. Candela esclusa.  
Aluminium. On demand we customized any laser cut. Candle not included.

- 9010
- 1019
- 2004
- 3002
- 6034
- 6018

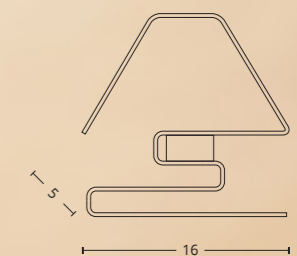

BRAND NEW

# LADY CAGE

BY MASSIMO ROSATI

L'ispirazione è la vecchia lampada da officina. La ruvida "cage lamp" veste il più classico dei paralumi e sogna di essere una vera Lady. Per l'occasione, l'abito nero, è d'obbligo...

*Inspired by the old-fashioned workshop light. The rough "cage lamp" shows off the most classic of shades and dreams of being a real Lady. A black outfit is a must for the occasion...*



Struttura in ferro (manico in plastica nera). Lunghezza cavo elettrico mt. 1,5. Attacco E27. Lampadina esclusa. Classe energetica: {A++ -> E}.

*Iron structure (black plastic handle). Length of the electrical cable mt. 1,5. Lampholder E27. Bulb not included. Energy class: {A++ -> E}.*

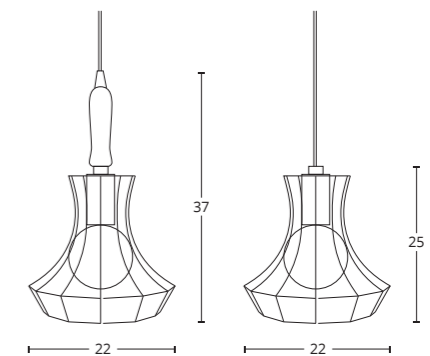

finitura  
finish

chrome	9005
--------	------

cavo  
cable

colore a scelta (vedi tabella colori)  
color on demand (see color chart)



# LADY CAGE

BY MASSIMO ROSATI

Struttura in ferro e manico in plastica nera. Lunghezza cavo elettrico mt. 3. Lampadina esclusa. Attacco E27. Classe energetica: {A++ -> E}.

*Iron structure and black plastic handle. Length of the electrical cable mt.3. Lampholder E27. Bulb not included. Energy class: {A++ -> E}.*

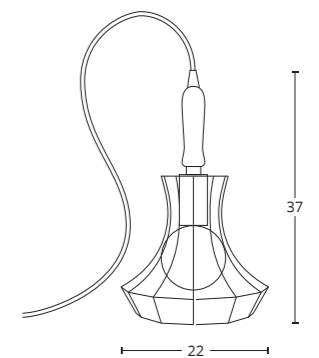

finitura  
finish chrome 9005

cavo  
cable colore a scelta (vedi tabella colori)  
color on demand (see color chart)

# QUEEN CAGE

BY MASSIMO ROSATI

“Lady Cage” diventa regina e si cinge il capo con una grande corona. Nella versione “chandelier” a 6, 8 e 12 luci, i cavi elettrici diventano parte integrante della lampada assumendo anche una funzione decorativa.

“Lady Cage” becomes “queen” and it encircles its head with a large crown. In the “chandelier version” in 6, 8 and 12 lights, the electrical fabric cables become an integral part of the lamp by taking a decorative function.

Struttura in ferro. Attacco E27. Lampadine escluse. Classe energetica: {A++ -> E}.  
Iron structure. Lampholder E27. Bulbs not included. Energy class: {A++ -> E}.

finitura  
finish 9005

cavo  
cable colore a scelta (vedi tabella colori)  
color on demand (see color chart)

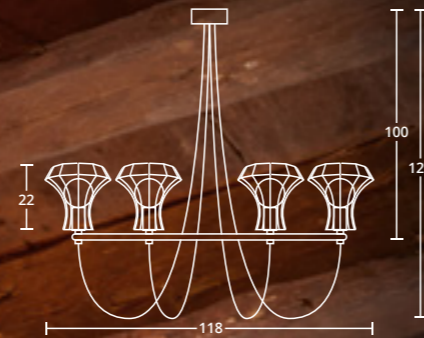

INDUSTRIAL  
**BRAND NEW**  
COLLECTION



**BRAND NEW**

# STITCH

BY MASSIMO ROSATI

Luce, metallo e cavo elettrico. Tre sono gli elementi che si fondono nella lampada Stitch. Il corpo slanciato in metallo, il cavo che vi disegna una lunga cucitura a contrasto, la sottile lama di luce a LED che si riflette sulla parete.

*Light, metal and electric cable. There are three elements that blend into the lamp Stitch. The sleek metal body, the cable that draws a long contrasting stitching, the thin blade of the LED light that is reflected on the wall.*

Struttura in ferro. Profilo porta LED in alluminio con copertura in plastica. Classe energetica: {A}.  
Iron structure. Profile with LED embedded in aluminium with plastic cover. Energy class: {A}.

1x46W Strip LED 220V 4000K 6000Lm Energy class A

- 9010
- 9005
- 7016
- 4005
- 3004

Cavo: colore a scelta (vedi tabella colori)  
Cable: color on demand (see color chart)

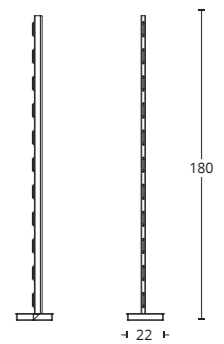

BRAND NEW



9010 9005 3002 3004 1019 6034

Ferro. Multistrato di faggio naturale oppure tinto noce medio.  
Classe energetica: {A}.  
Iron. Natural beech plywood or walnut medium. Energy class: {A}.

3x17W LED Ø100mm 220V 4000K Opal 1350Lm Energy class A



# INTERSECTIONS

BY STUDIO 14

Un cilindro in metallo sezionato da numerose lamelle di legno che giocano a scomporre la luce in settori. La luce diffusa da Intersections decora gli spazi che viviamo, proiettando la trama del diffusore ligneo che disegna sulle superfici zone di luce e di ombra frammentate.

*A metal cylinder dissected by numerous wooden slats that split the light into irregularly shaped areas. The scattered light created by Intersections decorates the spaces in which we live, projecting the texture of the wooden shade that draws light and fragmented shadow areas.*

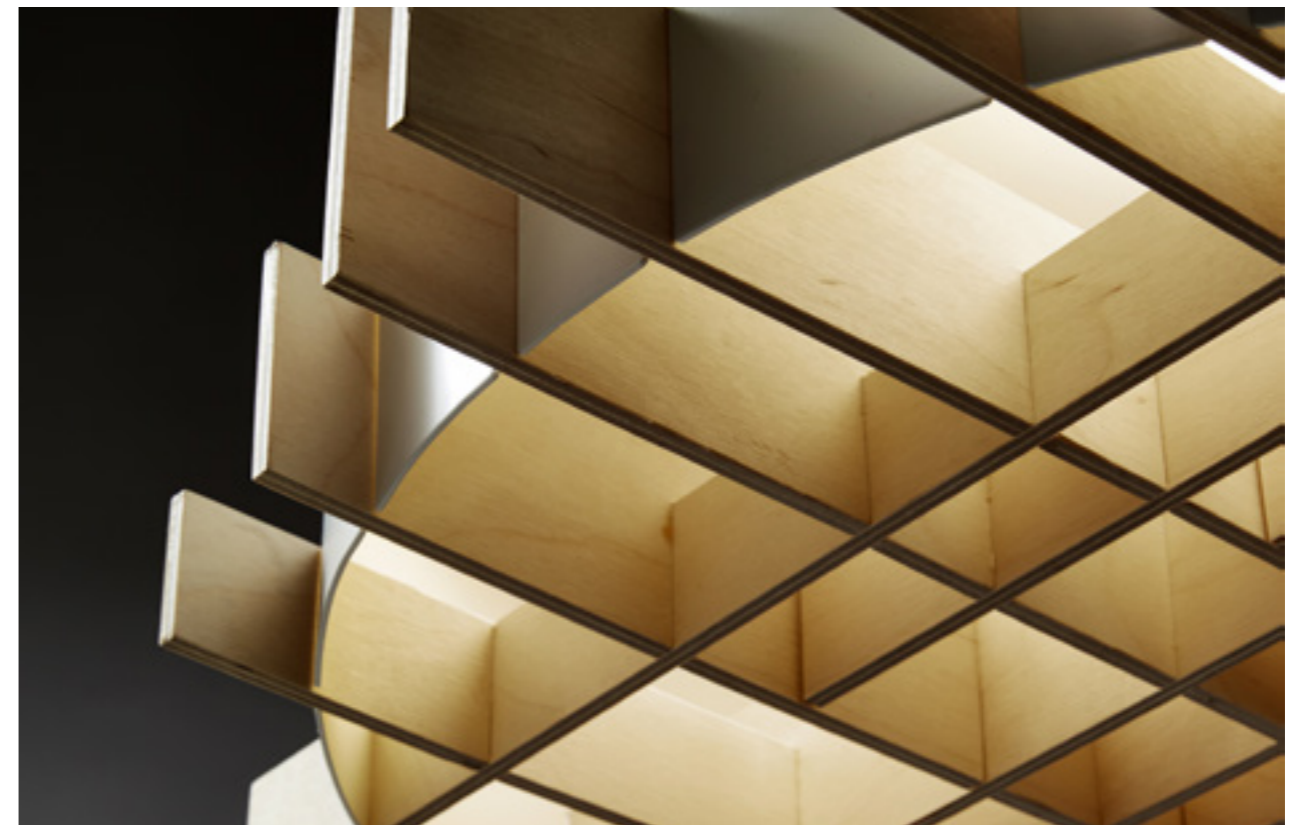



BRAND NEW

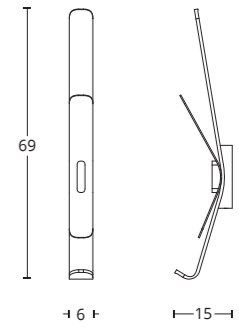

# BOOMERANG

BY STUDIO 14

Un segno scultoreo sulla parete. Modularità e versatilità. Leggerezza e forza. Una sottile lamella di legno curvato ne abbraccia una di alluminio, andando a formare l'appendiabiti BOOMERANG. Sia in versione singola che in trittico.

*A sculptural sign on the wall. Modularity and versatility. Lightness and strength. A thin reed of bentwood embraces another reed of aluminum, forming the coat-hanging system BOOMERANG, created single and triptych.*

Alluminio. Disponibile nei colori a catalogo (vedi tabella colori verniciature).

*Aluminium. Available in catalogue colors (see painted colors chart).*



# ANDROMEDA

BY PAOLO ULIAN

Andromeda è una lampada che può assumere infinite configurazioni formali a seconda di come vengono 'piegati' i vari elementi/diffusori esagonali.

*Andromeda is a lamp that can produce an infinite number of formal configurations depending on how the various hexagonal diffusers/elements are 'bent'.*

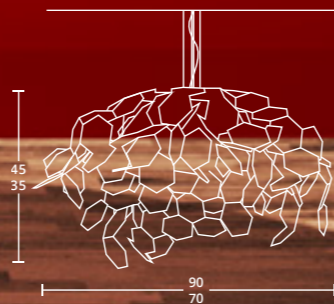
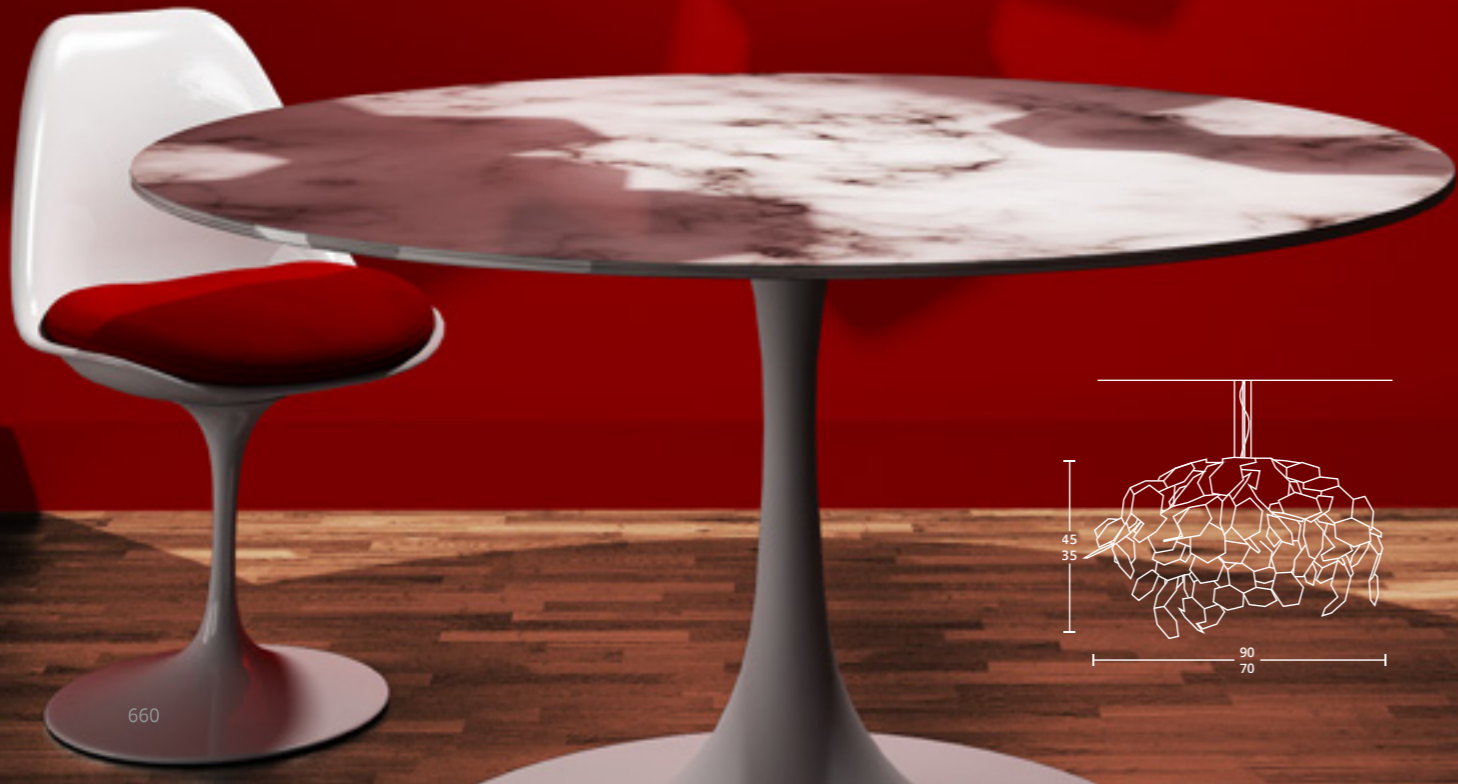

660



Alluminio. Attacco E27. Lampadina esclusa.  
Classe energetica: {A++ -> E}.  
Aluminium. Lampholder E27. Bulb not included. Energy class: {A++ -> E}.

9010

9005



670

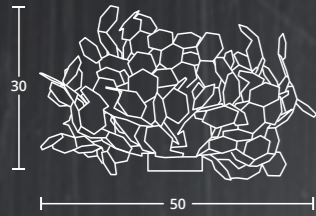

Alluminio. Classe energetica: {A}.  
Aluminium. Energy class: {A}.

1x7W LED Ø42mm 220Vac 3000K 430Lm  
Energy class A

# ANDROMEDA

APPLIQUE - BY PAOLO ULIAN



# ARIANNA

BY PAOLO ULIAN & CATERINA DI MICHELE

Una lampada come una bobina su cui arrotolare o srotolare il cavo elettrico per farlo arrivare in ogni parte della stanza, e anche più in là...

*A lamp that is like a spool on to which to wind or unwind the electric cable, allowing it reach every corner of the room, and further still...*

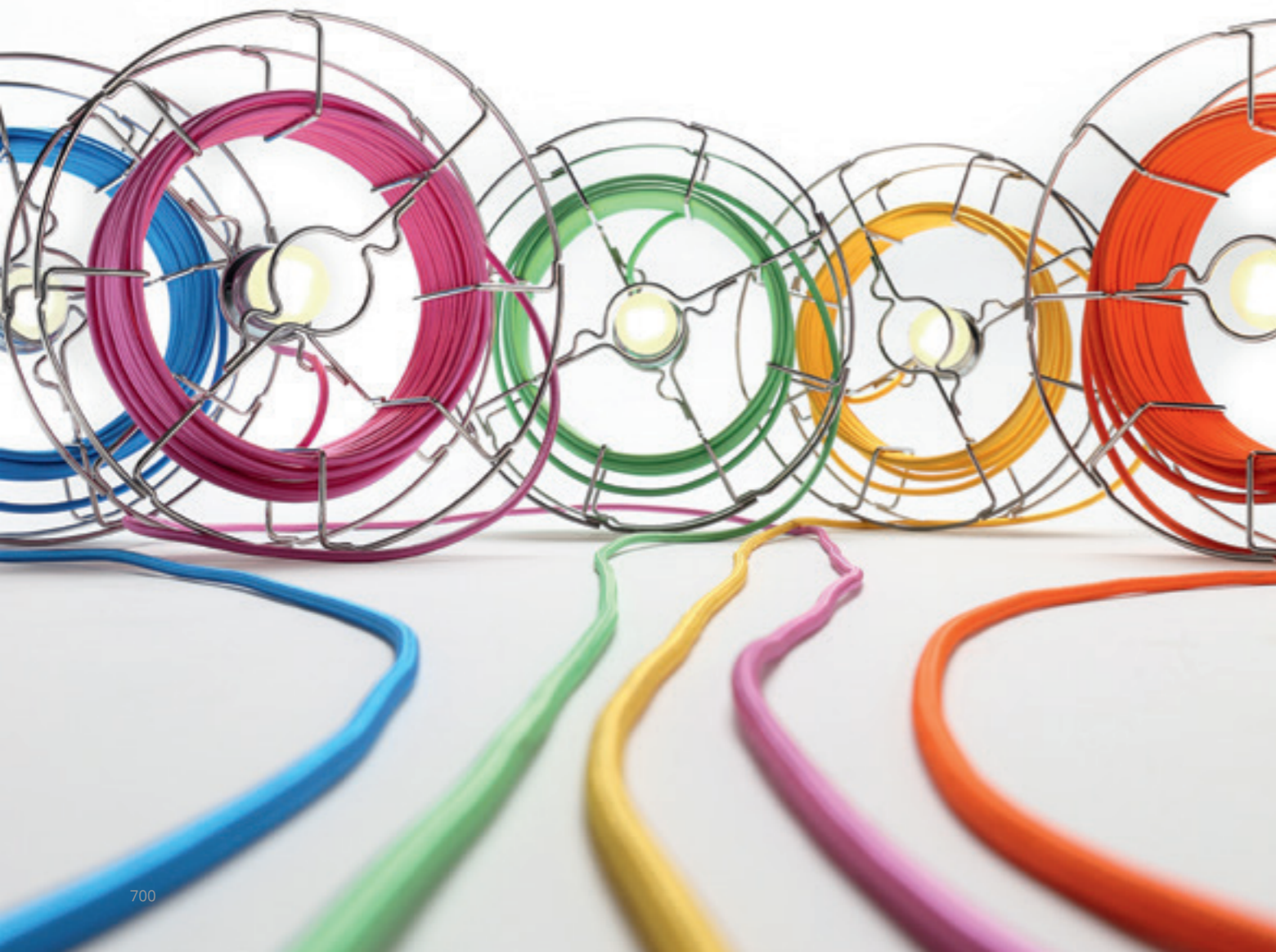

Ferro. Staffa per applique acciaio cromato. Attacco E27. Lampadina esclusa. Lunghezza cavo elettrico 15 m. Classe energetica: {A++ -> E}.

*Iron. Hooks for wall lamp in chrome steel. Lampholder E27. Bulb not included. Length of the electrical cable 15 m. Energy class: {A++ -> E}.*

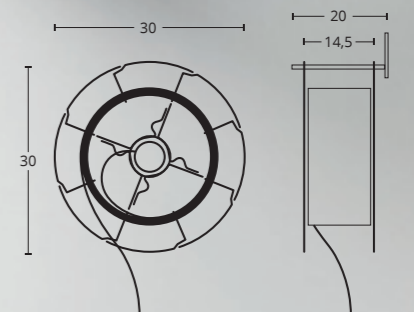

finitura  
finish chrome 9005

cavo  
cable colore a scelta (vedi tabella colori)  
color on demand (see color chart)

# BERLINO

BY FRANCO ZAVARISE

Tutto nasce da un'immagine che mi è rimasta impressa nella memoria. Una strada di Berlino illuminata da vecchi lampioni stradali.

*Everything springs from an image that is ingrained in the memory. A Berlin street lit by some old street lamps.*



Attacco E27. Lampadina esclusa. Classe energetica: {A++ -> E}.

Lampholder E27. Bulb not included. Energy class: {A++ -> E}.

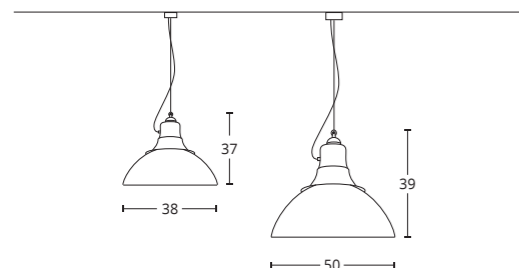

Supporto in alluminio satinato o ferro verniciato:  
Structure in satinated aluminium or painted iron:



Vetro prismatico      Prismatic glass  
Cavo trasparente o arancio      Transparent or orange cable





# GIÒ

BY FRANCO ZAVARISE

Giò è la sintesi di una ricerca formale sulle potenzialità espressive della tornitura. La sua bellezza sta proprio nell'equilibrio delle proporzioni.

*Giò is a précis of a formal study on the expressive capabilities of metal turning. Its beauty is to be found precisely in the balance of the proportions.*

Ferro. Attacco E27. Lampadina esclusa. Classe energetica: {A++ -> E}.  
Iron. Lampholder E27. Bulb not included. Energy class: {A++ -> E}.

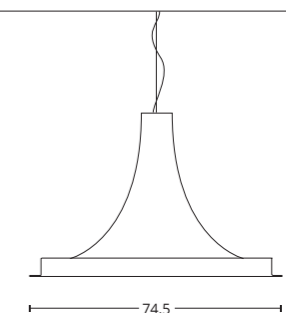

esterno outside	9005	9006	9010	3004	1003
interno inside	9010	o su richiesta or on demand			

INDUSTRIAL  
**BRAND NEW**  
COLLECTION



# OFFICINA

BY FRANCO ZAVARISE & MASSIMO ROSATI

La lampada Officina nasce dall'incontro fra due creativi uniti da passioni comuni: le archeologie industriali e le vecchie lampade da lavoro. Il risultato è una lampada dalle linee "ruvide" ma evocative; ispirata alle vecchie officine, ma pensata per tutte le "officine contemporanee".

Ferro. Cavo PVC grigio o arancio. Attacco E27. Lampadina esclusa. Classe energetica: {A++ -> E}.

The lamp Officina was born from the fellowship meeting between two designers united by common passions: the industrial archeology and the old style working lanterns. The result is a lamp with a "rough" but evocative shape, inspired to the old industrial shops atmosphere, but designed for all the "contemporary workshops".

Iron. Grey or orange PVC cable. Lampholder E27. Bulb not included. Energy class: {A++ -> E}.



# MINI MINI

OUTDOOR VERSION - BY FRANCO ZAVARISE

« Piccola fonte luminosa, come una piccola ma lucente stella nel cielo, Mini Mini nasce per essere integrata nel giardino. E' la coniugazione di funzionalità e rispetto dell'ambiente, in quanto Mini Mini non genera inquinamento luminoso e soprattutto si mimetizza nell'ambiente naturale grazie anche alla finitura ramata. L'esile stelo permette inoltre di dare a Mini Mini l'inclinazione desiderata.

*A Small light source, such as a small but shining star in the sky, Mini Mini is designed to be integrated into the garden. It is the conjugation of functionality and respect for the environment, as Mini Mini does not generate light pollution and mostly blends into the natural environment thanks to the copper finish. The slender stem allows to get to Mini Mini the desired angle and shape.* »

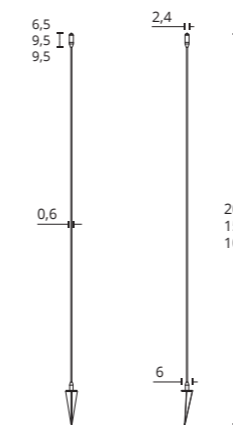
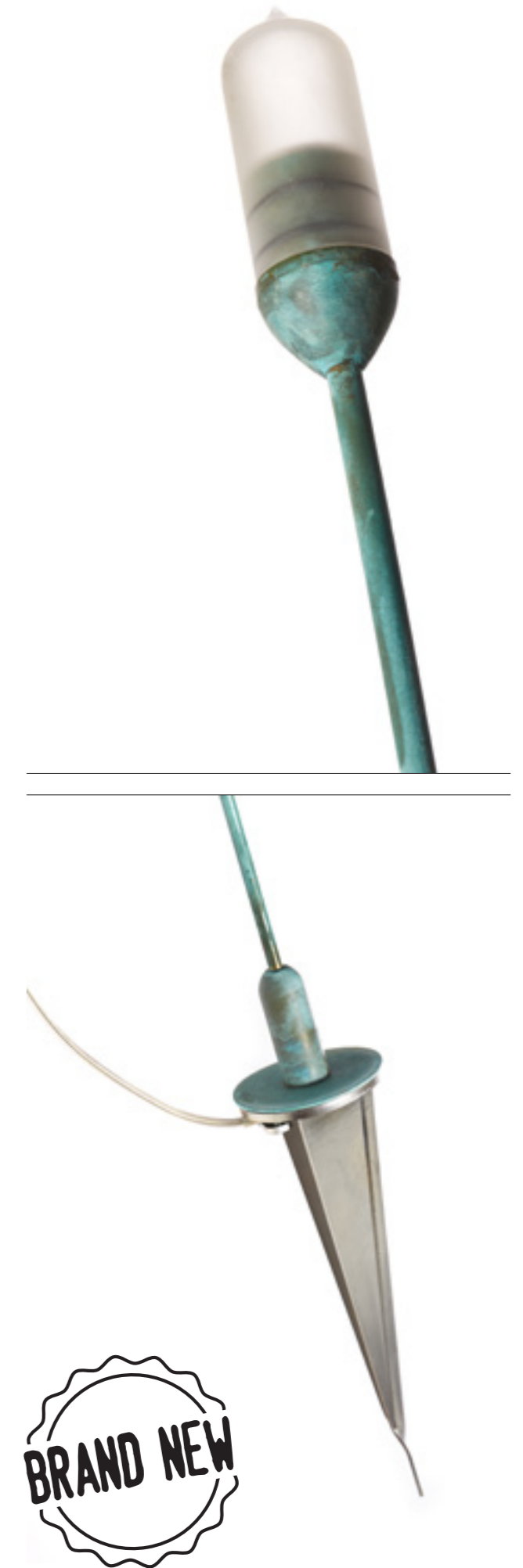

Ottone brunito o verde rame. Punto luce in vetro. Base con picchetto acciaio inox, cavo mt.10, IP55. Classe energetica: {A}.  
 Burnished brass or copper green. Light point in glass. Base with stainless steel picket, cable length 10 mt, IP55. Energy class: {A}.

1x1,5W G4 LED CERAMIC 12V 2700K 85Lm En. class A







# MINI MINI

INDOOR VERSION - BY FRANCO ZAVARISE

BRAND NEW

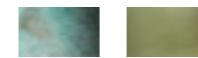
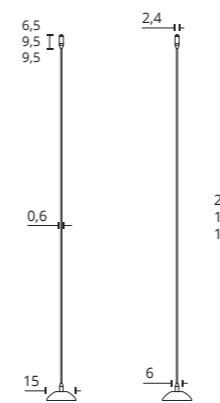

Ottone brunito o verde rame. Punto luce in vetro. Base Ø 15cm, con alimentazione a spina o a batteria ricaricabile (autonomia:3 ore). Classe energetica: {A}.  
*Burnished brass or copper green. Light point in glass. Base Ø 15 cm, with power pack plug or rechargeable battery (Battery life: 3 hours). Energy class: {A}.*

1x1,5W G4 LED CERAMIC 12V 2700K 85Lm Energy class A





# SODA

BY FRANCO ZAVARISE

Quando ho disegnato questa lampada è stato il primo nome che mi è venuto in mente perché ho pensato alla sua forma compatta e massiccia. Soda si ispira alle vecchie lampade industriali ma si ingentilisce con il suo interno colorato a contrasto o in foglia oro, argento o rame.

*When I designed this lamp was the first name that came into my mind because I thought to its compact and massive shape. Soda is inspired by the old industrial lamps but becomes more gentle thanks to the colorful interior or decorated with gold silver or copper leaf finish.*



Ferro. Cavo pvc grigio o arancio. Classe energetica: {A}.  
Iron. Grey or orange PVC cable. Energy class: {A}.  
1x17W LED Ø100mm 220V 4000K Opal 1350Lm En. class A

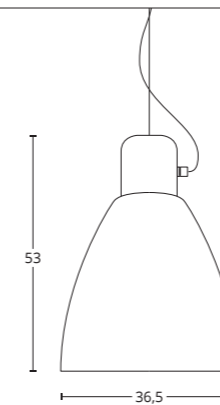

9010

9005

blue iron

Interno: colore personalizzabile su richiesta, foglia oro/  
argento/bronzo

*Inside: any color on demand, golden/silver/bronze leaf*

# ZAVAVA

CONTEMPORARY

# COLLE

# CTION

## 1962 BY FRANCO ZAVARISE

Lampada da terra con struttura in metallo verniciato. Disponibile in due misure, altezza 250 e 220 cm. Classe energetica: {A++ -> E} o {A}.

*Floor lamp with a painted metal structure. Available in two height sizes: 220cm and 250cm. Energy class: {A++ -> E} or {A}.*

1x23W E27 230V Ø120 4000°K energy saving Energy class A. Or 1x17W LED Ø100mm 220V 4000K Opal 1350Lm dimmable Energy class A

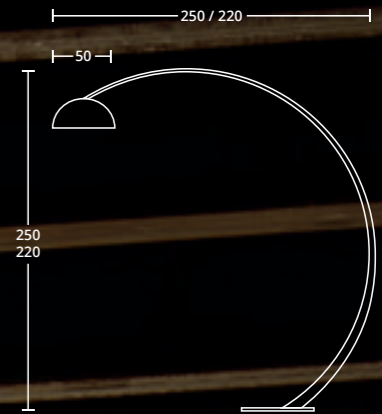

9010

9005

9006



# 101

BY FRANCO ZAVARISE

Sospensione in metallo verniciato con fascio di luce bianca a LED. Classe energetica: {A}.

*A suspension lamp in painted metal with a band of white LED lighting. Energy class: {A}.*

31x1W LED 350mA 3V 3000K 80Lm Energy class A

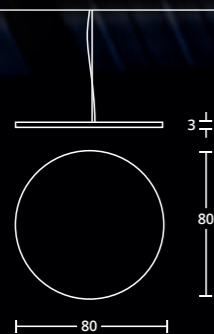

9010

# 201

BY FRANCO ZAVARISE

Sospensione in metallo verniciato con fascio di luce bianca a LED. Classe energetica: {A}.

*A suspension lamp in painted metal with a band of white LED lighting. Energy class: {A}.*

9010

31 LED 1,3W x 12V - 4000° / 6500° K Energy class A

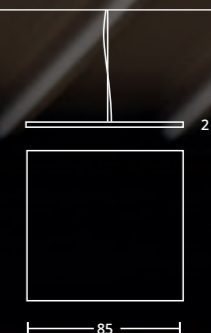

Facile e divertente sospensione da soffitto in metallo, disponibile in vari colori e adatta per gli ambienti più diversi. Questa lampada si presta ad una finitura assolutamente particolare, detta "Camaleonte". La finitura consiste nell'applicazione di uno strato di resina, successivamente lavorata a mano e verniciata in qualsiasi colore su richiesta.

*An easy and enjoyable metal suspension, available in different colors and suitable for any contemporary surroundings. This fitting is suitable to a very special finish, called "Camaleonte". It consists of the application of a layer of resin, that is worked by hand afterwards and painted in any color on demand.*

Ø40/50 ferro. Ø80 alluminio. Attacco E27 Lampadina esclusa oppure versione LED. Classe energetica: {A++ -> E} o {A}.  
 Ø40/50 iron. Ø80 aluminium. Lampholder E27, bulb not included or LED version. Energy class: {A++ -> E} or {A}.

1x17W LED Ø100mm 220V 4000K Opal 1350Lm Energy class A

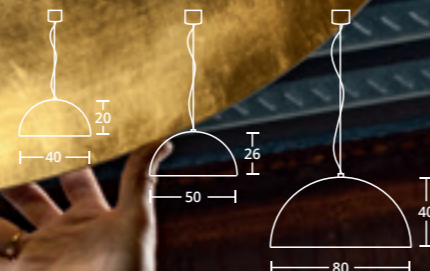

- esterno outside
- 9010
  - 9005
  - 1019
  - Camaleonte

interno inside  
 colore personalizzabile su richiesta, foglia oro/argento/bronzo o "camaleonte"  
*any color on demand, golden/silver/bronze leaf or "Camaleonte finish"*

Finitura Camaleonte  
*Camaleonte finish*

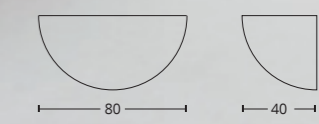

Questa semplice applique è disponibile esternamente nelle stesse finiture della sospensione, mentre l'interno è bianco 9010.

*This simple applique is available in the same finish as the pendant light for the outside, while the inside is white 9010.*

Finitura Camaleonte  
*Camaleonte finish*



# ALVIN

BY FRANCO ZAVARISE

Una grande cupola in metacrilato opalino o nero con interno verniciato (vedi lista colori fine catalogo) oppure in foglia oro/argento/bronzo.

*A large dome shape in opal or black methacrylate with a painted interior (see the list of colours at the end of the catalogue) or in gold/silver/bronze leaf.*

Attacco E27 Lampadina esclusa oppure versione LED.  
Classe energetica: {A++ → E} o {A}.  
Lampholder E27, bulb not included or LED version.  
Energy class: {A++ → E} or {A}.  
1x17W LED Ø100mm 220V 4000K Opal 1350Lm Energy class A

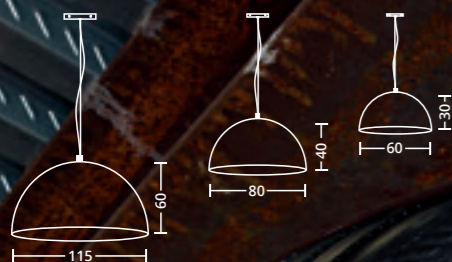

# ARCHITETTURA

BY CHRISTIAN PICCOLO

Applique da parete o da angolo in ferro verniciato.

*Applique suitable for wall or corner, painted iron.*

9010

9005

9006

3002

Energy class: {A++ → E}.  
1x80W T5 230V neon Energy class A

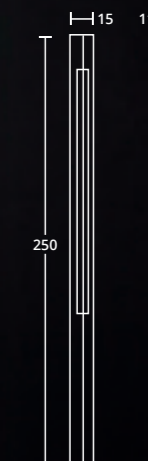

# BULL

BY FRANCO ZAVARISE

Lampada da sospensione in alluminio verniciato, disponibile in due misure: Ø5 x h40 e Ø10 x h50.

Suspension in painted aluminium, available in two sizes: Ø5 x h40 and Ø10 x h50.

9010

9005

3002

chrome

Classe energetica: {A++ -> E};  
Attacco Ø10: E27  
Attacco Ø5: GU10  
Lampadina esclusa

Energy class: {A++ -> E};  
Lampholder Ø10: E27  
Lampholder Ø5: GU10  
Bulb not included

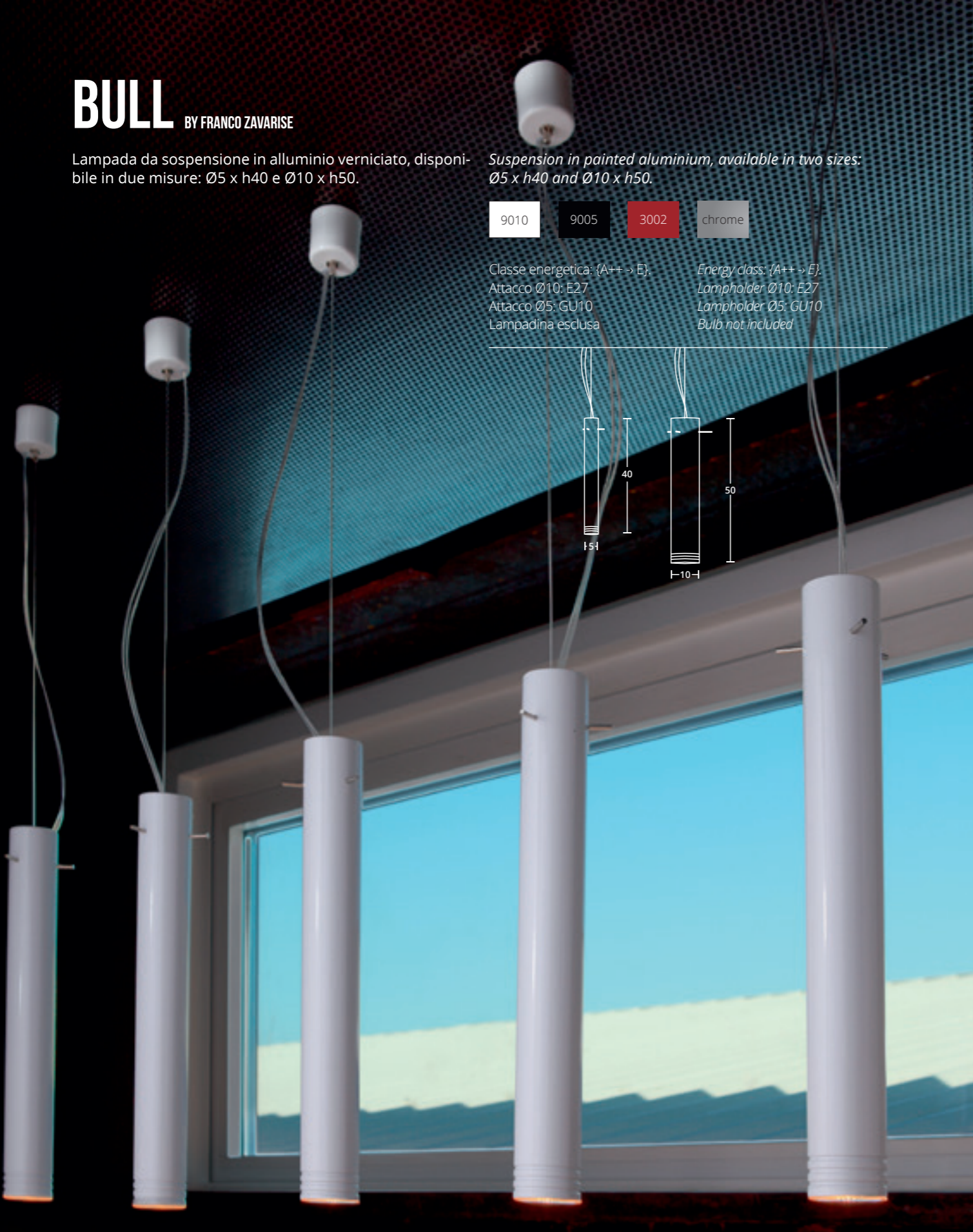
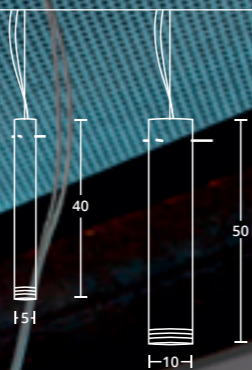



Attacco E27 Lampadina esclusa. Classe energetica: {A++ -> E}.  
Lampholder E27. Bulb not included. Energy class: {A++ -> E}.



## AURORA BY FRANCO ZAVARISE

Sospensione in metallo verniciato nero o bianco, con interno personalizzabile, anche in foglia oro/argento/bronzo.

*Suspension lamp in white or black painted metal, with customisable interior, even in gold/silver/bronze leaf.*



- 9010
- 9005
- 3002
- 9006

Energy class: {A++ -> E}  
1x39W T5 G5 230V neon Energy class A  
or 1x54W T5 G5 230V neon Energy class A



## CHEO BY FRANCO ZAVARISE

Applique realizzata in metallo verniciato con diffusore in metacrilato. Lunghezza cm 90 o cm 120. Diffusione della luce su entrambi i lati.

*An applique created in painted metal with a methacrylate diffuser. 90cm or 120cm long. Lighting diffusion upside and downside.*



# COBI

BY FRANCO ZAVARISE

Sospensione o plafoniera in metallo verniciato e metacrilato trasparente prismatico.

*Suspension or ceiling light in painted metal and transparent prismatic methacrylate.*



Attacco E27. Lampadina esclusa. Classe energetica: {A++ -> E}.  
Lampholder E27. Bulb not included. Energy class: {A++ -> E}.

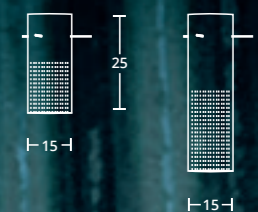
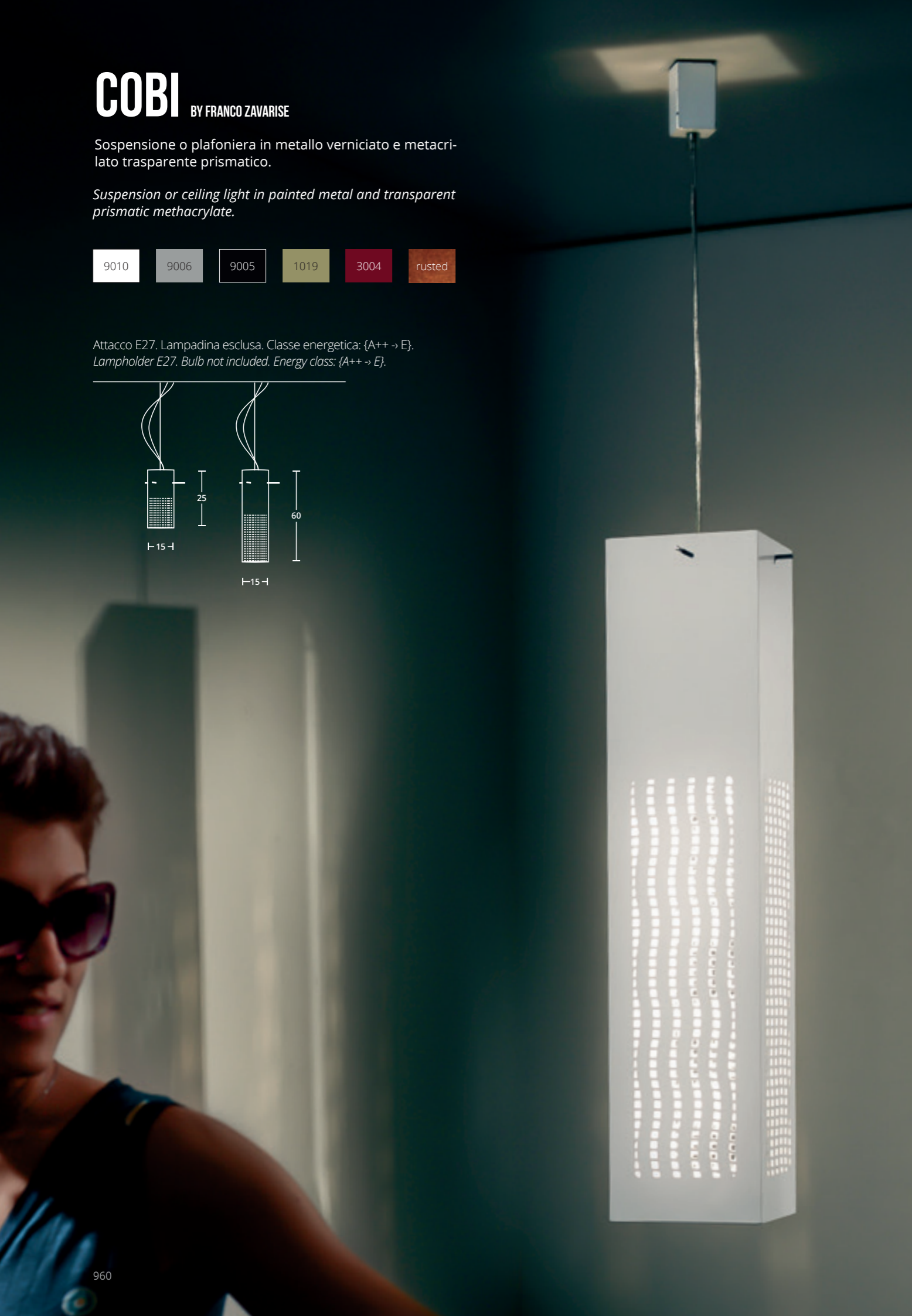
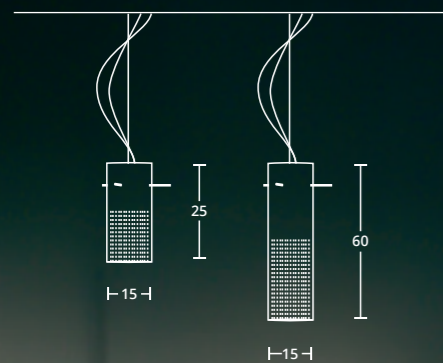

# CONO 1

BY FRANCO ZAVARISE

Lampada a sospensione in metallo verniciato. Disponibile nei colori a catalogo, anche con cavo rivestito in tessuto in colori a contrasto. (Vedi tabella colori a fine catalogo)

*Suspension lamp in painted metal. Available in catalogue colours and also with a fabric covered cable in contrasting colours. (See color chart at the end of the catalogue)*



Attacco E27. Lampadina esclusa. Classe energ.: {A++ -> E}.  
Lampholder E27. Bulb not included. Energy class: {A++ -> E}.



Classe energetica: {A}.  
Energy class: {A}.  
1x7W LED Ø42mm 7W 220Vac 3000K 430Lm  
Energy class A

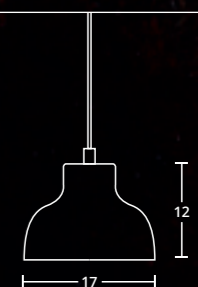

# COCO 1

BY FRANCO ZAVARISE

Lampada a sospensione in metallo verniciato. Disponibile nei colori a catalogo, anche con cavo rivestito in tessuto in colori a contrasto. (Vedi tabella colori a fine catalogo)

*Suspension lamp in painted metal. Available in catalogue colours and also with a fabric covered cable in contrasting colours. (See color chart at the end of the catalogue)*



Classe energetica: {A}.  
 Energy class: {A}.  
 6x7W LED Ø42mm 7W 220Vac 3000K 430Lm  
 Energy class A

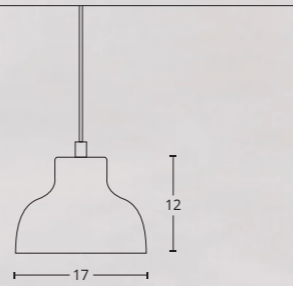

## COCO 6 BY FRANCO ZAVARISE

Lampada a sospensione in metallo verniciato. Disponibile nei colori a catalogo, anche con cavo rivestito in tessuto in colori a contrasto. (Vedi tabella colori a fine catalogo)

*Suspension lamp in painted metal. Available in catalogue colours and also with a fabric covered cable in contrasting colours. (See color chart at the end of the catalogue)*



Attacco E27. Lampadina esclusa.  
 Classe energ.: {A++ -> E}.

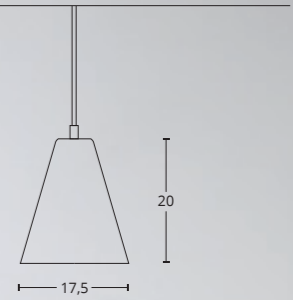

## CONO 6 BY FRANCO ZAVARISE

Lampada a sospensione in metallo verniciato. Disponibile nei colori a catalogo, anche con cavo rivestito in tessuto in colori a contrasto. (Vedi tabella colori a fine catalogo)

*Suspension lamp in painted metal. Available in catalogue colours and also with a fabric covered cable in contrasting colours. (See color chart at the end of the catalogue)*

# CRACK

BY RAUL GIROTTO

Disponibile nelle versioni applique e tavolo, è realizzata in metallo verniciato. La luce della lampadina è attenuata da un rivestimento in plexiglas. Disponibile in finitura ruggine e nei seguenti colori:

Available in applique and table versions, created in painted metal. The bulb's light is softened by a Plexiglas covering. Available in rusted finish and in the colors as follows:



Classe energetica: {A++ -> E}.  
Energy class: {A++ -> E}.

1x60W E14 230V Energy class D

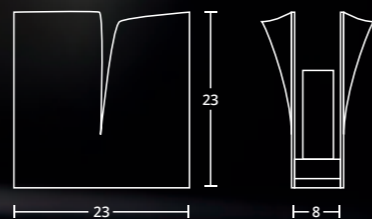

Classe energetica: {A++ -> E}.  
Energy class: {A++ -> E}.

1x60W E14 230V Energy class D

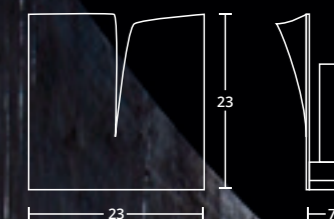



# DRIVE

BY FRANCO ZAVARISE

Sospensione in metallo con lavorazione a nido d'ape nella parte superiore ottenuta con taglio laser.

*Metal suspension lamp with a honeycomb finish on the upper part created with laser cutting.*

- 9010
- 9006
- 9005
- 4008
- 5024

Attacco E27. Lampadina esclusa. Classe energ.: {A++ → E}.  
Lampholder E27. Bulb not included. Energy class: {A++ → E}.

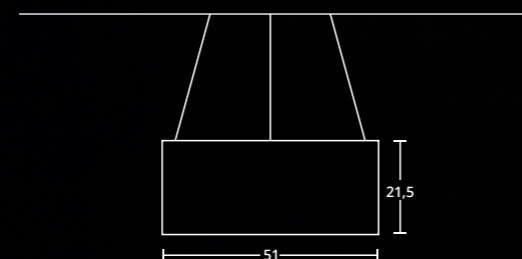

# ECLISSI

BY FRANCO ZAVARISE

Applique in metallo verniciato con lampadina "circolina" a vista inclusa.

*Applique in painted metal with a visible circuline bulb included.*

- 9010
- 9005
- 3002
- 3004

Classe energetica: {A++ → B}.  
Energy class: {A++ → B}.  
1x40W G10q 230V Circular bulb En. class B

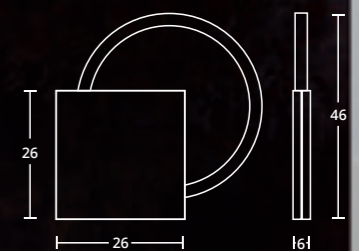

# ERIS

BY FRANCO ZAVARISE

Sospensione in metallo verniciato disponibile nella versione con o senza fori.

*Suspension lamp in painted metal and available in a version either with or without holes.*

9010

9005

bronze

black

Attacco E27. Lampadina esclusa. Classe energ.: {A++ → E};  
Lampholder E27. Bulb not included. Energy class: {A++ → E};

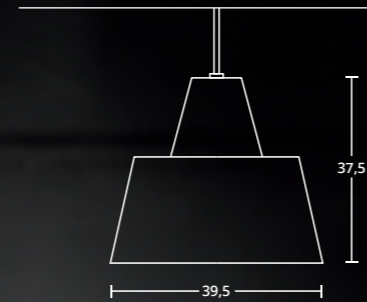

# FIRE

BY FRANCO ZAVARISE

Torcia con struttura in metallo verniciato nei colori a catalogo e parte superiore in acciaio satinato. Utilizza come combustibile olio per torce alla citronella, 100% vegetale. Autonomia: circa 6 ore.

*Torch with metal structure painted in catalogue colours and upper part in satin finish steel. It uses as combustible an oil for citronella torches, 100% vegetables. Duration: approximately 6 hours.*



# HEDROM

BY FRANCO ZAVARISE

Sospensione di forma geodetica, con facce esagonali in metacrilato prismatico trasparente e elementi di giuntura in alluminio. È disponibile in due versioni: a forma sferica e a cupola.

*Geodetic shaped suspension lamp with hexagonal faces in transparent prismatic methacrylate and connecting elements in aluminium. Available in two versions: spherical and dome shaped.*

Attacco E27. Lampadina esclusa. Classe energ.: {A++ -> E}.  
Lampholder E27. Bulb not included. Energy class: {A++ -> E}.

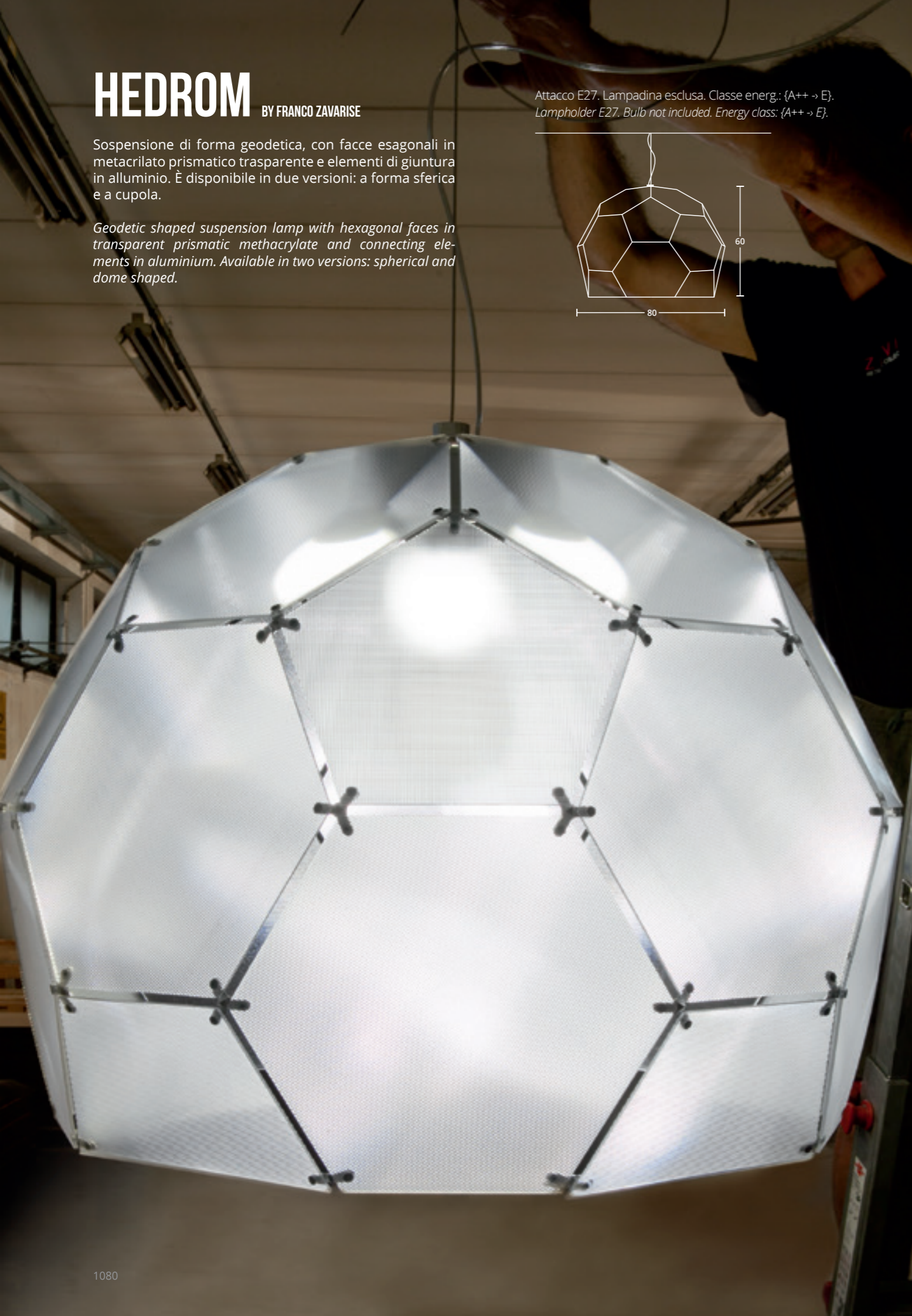
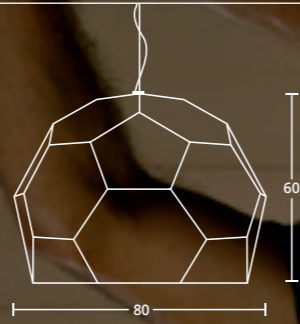

Attacco E27. Lampadina esclusa. Classe energ.: {A++ -> E}.  
Lampholder E27. Bulb not included. Energy class: {A++ -> E}.

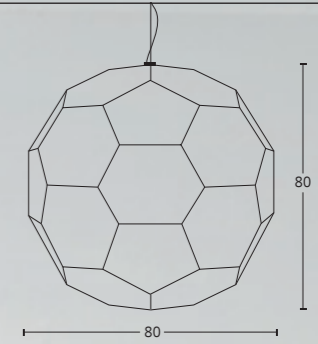

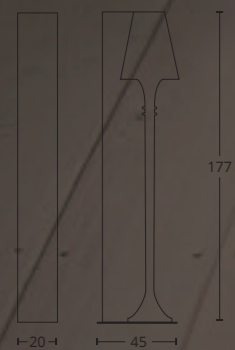

Classe energetica: {A}.  
Energy class: {A}.

1x37W LED Line 12V 3000K (2700Lm) or 4000K (2900Lm) dimmerable Energy class A

# LOREN BY FRANCO ZAVARISE

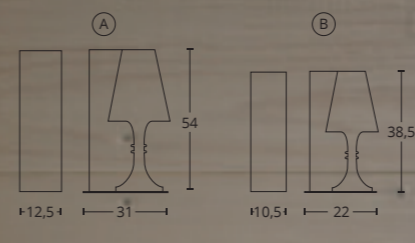

Classe energetica: {A}.  
Energy class: {A}.

(A) 1x9,63W LED Line 12V 3000K (700Lm) or 4000K (750Lm) dimmerable Energy class A  
(B) 1x6,87W LED Line 12V 3000K (500Lm) or 4000K (530Lm) dimmerable Energy class A

Lampada con struttura in metallo verniciato. Disponibile nelle versioni terra (h177) e tavolo (h54 & h38,5), destre o sinistre. Finitura interna in foglia oro/argento/bronzo, finitura esterna nei seguenti colori:

Lamp with a painted metal structure available in floor (h177) and table (h54 & h38,5) versions, in both right and left direction. Inner finish in golden/silver/bronze leaf, external finish in the colors as follows:

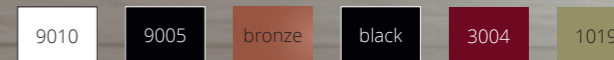





# OCIU BY FRANCO ZAVARISE

Sospensione di grandi dimensioni (cm.185) in metacrilato bianco o nero con dettagli in alluminio verniciato. All'interno presenta un diffusore a forma di globo diametro cm.50 in polimetacrilato. E' disponibile anche la versione con finitura esterna "camaleonte", che consiste nell'applicazione di uno strato di resina, successivamente lavorata a mano e verniciata in qualsiasi colore su richiesta. Finitura interna personalizzabile nei colori a catalogo e in foglia oro/argento/bronzo.

*A large-sized suspension lamp (185 cm.diameter) in white or black methacrylate with details in painted aluminium. In the inside the fitting has a polymethacrylate diffuser in a global shape cm.50. It's also available the outside finish called "Camaleonte", that consists of the application of a layer of resin, that is worked by hand afterwards and painted in any color on demand. The inner finish is customizable in any color of the catalogue, as well as in golden/silver/bronze leaf.*

Il diffusore a forma di globo diametro cm.50 in polimetacrilato.  
*The polymethacrylate diffuser in a global shape cm.50*

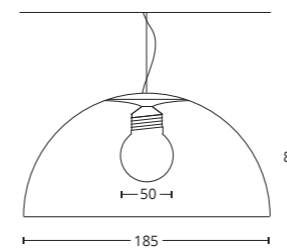

Classe energetica: {A++ → E}.  
 Energy class: {A++ → E}.

1x205W E27 230V 3000°K Halogen or 4x17W LED Ø100mm 220V 4000K Opale 1350Lm dimmerable Energy class C



9010

Classe energetica: {A}.  
Energy class: {A}.

1x35W Strip LED 220V 4000K 5000Lm dimmerable Energy class A

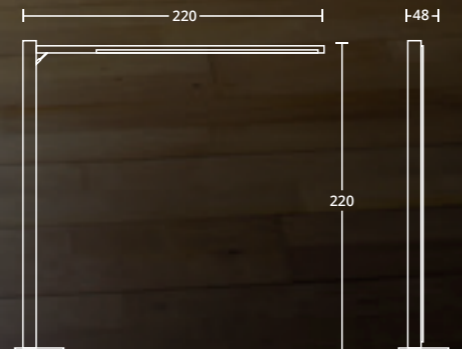

**MOVIE** BY CHRISTIAN PICCOLO

Lampada da terra in metallo verniciato bianco, con apertura automatica tramite pistone a gas cromato.

Floor lamp in white painted metal, with automatic opening via a chrome plated gas piston.

**Z5030** BY FRANCO ZAVARISE

Piantana da terra in alluminio con finitura trasparente e base in ferro verniciato nei seguenti colori:

Floor standing lamp in aluminium with a glossy finish and the base in painted iron in the colors as follows:

- 3002
- 3004
- 4008
- 2004
- 6018

Classe energetica: {A}.  
Energy class: {A}.

1x48W LED Line 24V 4000K 1440Lm Energy class A

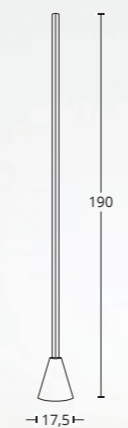

# ZAVAVA

METAL FURNITURE

# COLLECTION

# SECTION

**349** BY FRANCO ZAVARISE

Libreria a muro "snodata", modulare e componibile, realizzata in metallo verniciato nei colori a catalogo e in finitura ruggine.

*Wall-mounted modular bookshelf, created in metal painted in catalogue colours and in a rust finish.*





## STEEL BY FRANCO ZAVARISE

Libreria con attacco a muro nella parte superiore, numero ripiani personalizzabile, disponibile in finitura ruggine o in ferro blu di laminazione.

*Bookshelf with wall fixing in the upper part, customisable number of shelves, available in a rust finish or in blue iron.*

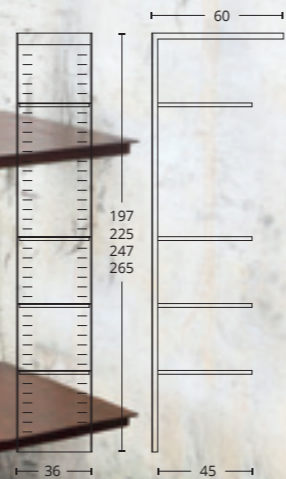

## SILERIA BY FRANCO ZAVARISE

Libreria componibile con struttura in metallo, disponibile in finitura ruggine e nei seguenti colori: 9010, 9005, 9006. Articolo venduto non assemblato.

*Modular metal bookcase available in rusted finish and in the colors as follows: 9010, 9005, 9006. Item sold disassembled.*

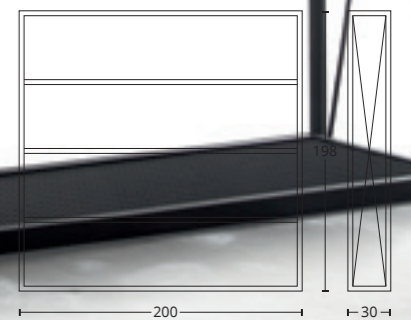

# TICO BIG

BY FRANCO ZAVARISE

Libreria componibile in alluminio, disponibile in diverse finiture, anche con interno in colore a contrasto. Nella versione a soffitto, il tubo centrale di sostegno può essere regolato in base all'altezza della stanza.

*Modular bookshelf in aluminium, available in different finishes and also with contrasting interior colour. In the ceiling version the central supporting pole can be adjusted to fit the height of the room.*



# TICO SMALL

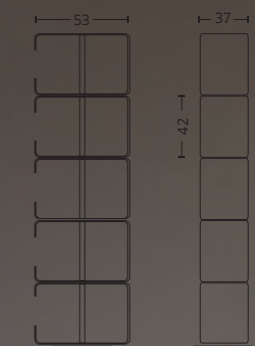

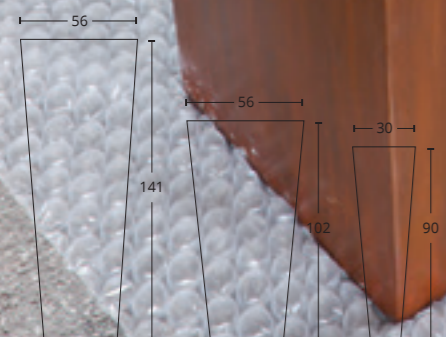

## ALCO BY FRANCO ZAVARISE

Vaso realizzato in metallo, con sistema di drenaggio acqua.

Vase made out of metal, with water drain system.

- 9010
- 9005
- 9006
- rusted

# ZOOMA & SGABEL BY FRANCO ZAVARISE

Tavolo con struttura componibile in metallo a vari elementi nei colori bianco e grigio. Sgabello in metallo con struttura bianca, poggiapiedi cromato e seduta in ecopelle.

Table with modular metal structure in various metal elements in white and grey. Metal stool with white structure, chrome-plated footrest and imitation leather seat.

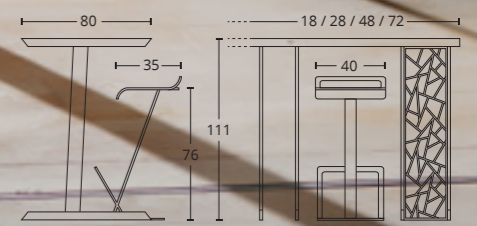



# JOOKE

BY DELINEODSIGN & FRANCO ZAVARISE

Sgabello in ferro blu di laminazione trattato con protettivo trasparente, girevole e regolabile in altezza da un minimo di 65 cm a un massimo di 85 cm. Disponibile anche in finitura verniciata nero opaco RAL 9005.

*Stool in blue iron, treated with a protective transparent lacquering. It is swivel seat adjustable in height from a minimum of 65 cm. to a maximum of 85 cm. Also available in matt black finish RAL 9005.*

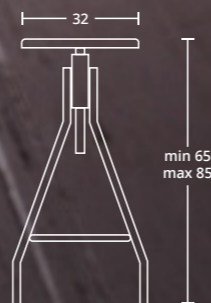

# TANK

BY FRANCO ZAVARISE

Adatti ad ogni ambiente, questi bidoni in ferro, chiusi su entrambi i lati possono essere utilizzati come tavolini d'appoggio o come espositori. Sono disponibili in varie misure e in tutti i colori a catalogo.

*Suitable for any environment, these bins made out of iron, are closed on both sides and available in various sizes and in all catalogue colors. They can be easily used as funny side-tables or as exhibition supports.*

- Ø 60 x h. 110
- Ø 60 x h. 88
- Ø 60 x h. 60
- Ø 60 x h. 45
- Ø 60 x h. 31
- Ø 60 x h. 14
- Ø 47 x h. 76
- Ø 47 x h. 54
- Ø 47 x h. 26



# TABELLA COLORI / COLOUR CHART

## COLORI VERNICIATURE PAINTED COLORS

	RAL 9006 Grigio Alluminio / Aluminum Grey
	RAL 9005 Nero intenso / Jet black
	RAL 9010 Bianco puro / Pure white
	RAL 3002 Rosso carminio / Carmine red
	RAL 3004 Rosso porpora / Purple red
	RAL 4005 Lilla bluastro / Blue lilac
	RAL 4008 Violetto segnale / Signal violet
	RAL 1019 Beige grigiastro / Grey beige
	RAL 2004 Arancio puro / Pure orange
	RAL 1003 Giallo segnale / Signal yellow
	RAL 6034 Turchese pastello / Pastel turquoise
	RAL 6018 Verde giallastro / Yellow green
	RAL 6005 Verde muschio / Moss green
	RAL 5024 Blu pastello / Pastel blue
	RAL 5010 Blu genziana / Gentian blue
	RAL 7006 Grigio beige / Beige grey
	RAL 7016 Grigio antracite / Anthracite grey
	Grigio metallizzato / Metalized grey
	Bronzo metallizzato / Metalized bronze
	Nero micaceo / Special matt black

COLORI RAL: disponibili sia lucidi che opachi  
RAL COLORS: available in both glossy and matt

## FINITURE SPECIALI SPECIAL FINISHES

	Finitura ramata / Copper finish
	Finitura Camaleonte / Camaleonte finish
	Finitura ruggine / Rusted finish
	Finitura cromata / Chrome finish
	Ferro blu di laminazione / Blue iron
	Finitura verde rame / Copper green
	Finitura ottone brunito / Burnished brass

La finitura ruggine di ZAVA é assolutamente eco-sostenibile: non viene utilizzato alcun acido per ottenerla. Il prodotto viene lasciato all'aperto e attraverso un processo naturale si ottiene l'effetto ruggine. E' importante saperlo perché questo trattamento richiede un tempo più lungo rispetto ai trattamenti chimici, che varia dalle 3 alle 4 settimane.

*The rusted finish of ZAVA is obtained by a totally eco-friendly procedure: we do not use any chemical acid. The object is left in open air and through a natural process, finally we obtain the rusted effect. It is very important to mention it because the lead time of ZAVA to get the rusted treatment is of about 3-4 weeks time.*

## COLORI RIVESTIMENTO IN TESSUTO DEL CAVO ELETTRICO TRIPOLARE COLOURS OF FABRIC SHEATHING FOR THREE WIRE ELECTRIC CABLE

	Rayon rosso scarlatto / Scarlet red rayon
	Rayon giallo mais / Maize yellow rayon
	Rayon arancio / Orange rayon
	Rayon verde prato / Lawn green rayon
	Rayon azzurro royal / Royal azure blue rayon
	Rayon nero / Black rayon
	Rayon bianco / White rayon
	Rayon ciclamino / Cyclamen rayon
	Poliestere grigio topo / Mouse grey colour

# SIMBOLI / SYMBOLS



Attesta la conformità del prodotto alle disposizioni delle direttive comunitarie.  
*Certify compliance for the product of the community directives.*



Prodotto resistente all'immersione temporanea. L'icona, dove presente, fa riferimento al corpo lampada.  
*Product temporary resistant to immersion. The icon, whether it is, refers to lamp body.*



Ai sensi della direttiva 2002/96/CE, il prodotto, alla fine della sua vita utile, non deve essere smaltito come rifiuto urbano.  
*Under the directive 2002/96/CE, the product, at the end of its life, mustn't be disposed of as urban waste.*

I dati riportati in questo catalogo sono indicativi e non costituiscono impegno da parte di ZAVA che si riserva il diritto di apportare tutte le modifiche e migliorie che riterrà necessarie senza l'obbligo di preavviso. Tutti i modelli rappresentati in questo catalogo portano la marcatura CE. La marcatura CE attesta che gli apparecchi d'illuminazione rispondono a tutti i requisiti minimi essenziali richiesti dalla Direttiva Comunitaria CEE 73/23 e relativa modifica CEE 93/68. A tale proposito, gli stessi apparecchi, sono stati progettati e costruiti in conformità alle Norme armonizzate CEI EN 60598-1 - VIII EDIZIONE. I nostri uffici commerciali rimangono a vostra completa disposizione per qualsiasi ulteriore delucidazione. I colori riportati nel catalogo sono indicativi. Tutte le misure sono espresse in centimetri.

*Description and details in this brochure are generic and are not binding. ZAVA reserves the right to make all necessary amendments and improvements to its fixtures, without any prior advise. All models included in this catalogue have a CE mark. The CE mark confirms that the fixtures correspond to the main requirements of the European community directives CEE 73/23 and relevant amendment CEE 93/68. In regards hereof all products have been developed and constructed accordingly the harmonized standard CEI EN 60598-1 - VIII EDITION. For further information, our trade departments are at your disposal. The colours illustrated in the catalogue are generic. All measures are understood in centimeters.*

Graphic design: Webian.it  
Photographer: Paolo Gamelli  
3D Rendering: Studio 14  
Print: Grafiche Vianello (June 2014)



**ZAVA**

via padova, 48 / 31041 cornuda / tv / ita  
t. +39 0423 639907 / f. +39 0423 821639  
contatto@zavaluce.it / www.zavaluce.it